

*Good 'Duck* 10101

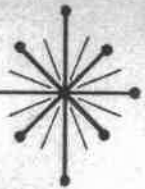

# SERVICE MANUAL



MODELS —

**DNS-80**

**DNS-110**

**DNS-150**



## WARRANTY AND ORDERING PROCEDURE

WARRANTY

## LIMITS OF THE WARRANTY

This warranty contract covers only equipment either manufactured or sold by Dixie-Narco, Inc. after June 10, 1957. The Company does not take any responsibility that is not listed in this warranty; and it does not authorize any person to agree to take for Dixie-Narco, Inc. any responsibility that is not listed in this warranty.

## WHO THE WARRANTY IS MADE TO

This warranty is made only to the firm or person who buys a new Dixie-Narco cooler from a Bottler. If the firm or person who buys the cooler resells it, the cooler will no longer be covered by this warranty.

## WHAT DIXIE-NARCO, INC. WILL DO UNDER THE WARRANTY

Dixie-Narco, Inc. will either repair or replace, at their expense, a cooler or parts of a cooler (except refrigerant driers) if:

1. The parts are still within either the Base Period of the warranty, or the Additional Period of the warranty.
2. Dixie-Narco, Inc. checks the cooler or part and finds that it will not work because there is something wrong, either with the material used, or the way it was made.
3. The cooler has had reasonable care and normal use and service.
4. The cooler is located within either the continental boundaries of the United States of America, its territories and possessions or the Dominion of Canada.

Dixie-Narco, Inc. will not repair or replace parts of a cooler at their expense if:

1. The cooler either has been abused, misused, damaged during shipment or has been damaged by fire, flood, civil disorder, or Act of God.
2. The cooler has had changes made to it by service not authorized by Dixie-Narco, Inc.

## HOW LONG THE COOLER IS GUARANTEED

All parts of a cooler are guaranteed under the terms of this warranty during the Base Period of the warranty; that is, either for one year from the date of installation of the cooler, or for 15 months from the date of the sale of the cooler to the Bottler, whichever period may end first.

## WARRANTY AND ORDERING PROCEDURE (Cont.)

WARRANTY (Cont.)

## HOW LONG THE COOLER IS GUARANTEED (Cont.)

The hermetically sealed refrigeration system, consisting of the compressor, the condenser and evaporator that is supplied by Dixie-Narco, Inc., is guaranteed for an Additional Period, the 4 years that follow the end of the Base Period of the warranty.

## SHIPPING CHARGES

Parts of coolers, sent back to Dixie-Narco, Inc. for repair or replacement shall move, charges prepaid to Dixie-Narco, Inc. unless the parts are within warranty and then the parts can be returned charges collect. Parts of coolers will be sent back to the customer from Dixie-Narco, Inc., Ranson, West Virginia charges collect, unless the parts are within warranty and then parts will be returned, charges prepaid.

## ORDERING PROCEDURE

## VENDING &amp; REFRIGERATION PARTS

Order all vending and refrigeration parts from Service Department, Dixie-Narco, Inc., Ranson, West Virginia.

To avoid delay of credit issuance, when due, furnish the Dixie-Narco cabinet serial number and the Original Date of Installation along with all other information requested on the Dixie-Narco return material tag. Return material tags will be furnished upon request.

## A C C E S S O R I E S

Cooler Model	Kit	Kit Number
DNS-80 DNS-110 DNS-150	Caster Kit With Caster Lock	C52-01-60
	Coin Box Lock Kit	ADN15-0012
	Totalizing Counter Kit	A52-01-80
DNS-80	U.S. Public Health Kit	71-01-50
DNS-110 DNS-150	U. S. Public Health Kit	73-01-50
DNS-80 DNS-110	Illuminated Sign Kit (Printed Glass)	73-01-60
	*Illuminated Sign Kit (Mylar-Clear Glass)	73-01-70
	*Metal Sign Kit (With Clear Glass)	73-01-80
DNS-150	Illuminated Sign Kit (Printed Glass)	74-01-40
	*Illuminated Sign Kit (Mylar-Clear Glass)	74-01-50
	*Metal Sign Kit (With Clear Glass)	74-01-60

\* Can Be Used Only On: DNS-80 S/N 340-528 and higher  
 DNS-110 S/N 360-301 and higher  
 DNS-150 S/N 400-000 and higher



T I T L E P A G E

MODEL DNS-80

Working Space  
width 28"  
front clearance 55-7/8"  
height 56-1/8"

Vend Capacity

80 standard bottles  
80 10 oz. King Size Bottles  
72 12 oz. King Size Bottles

Pre-Cool Capacity

33 standard bottles  
27 10 oz. King Size Bottles  
22 12 oz. King Size Bottles

Dimensions

28" x 21-7/8" x 56-1/8"



DOMESTIC SHIPPING WEIGHT

DNS-80 365 lbs.  
DNS-110 410 lbs.  
DNS-150 472 lbs.

MODEL DNS-110

Working Space  
width 28"  
front clearance 55-7/8"  
height 65-7/16"

Vend Capacity

110 standard bottles  
110 10 oz. King Size Bottles  
99 12 oz. King Size Bottles

Pre-Cool Capacity

33 standard bottles  
27 10 oz. King Size Bottles  
22 12 oz. King Size Bottles

Dimensions

28" x 21-7/8" x 65-7/16"

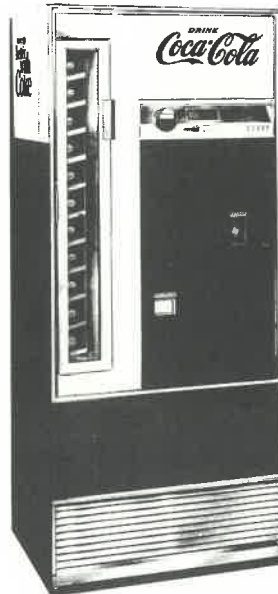

MODEL DNS-150

Working Space  
width 28"  
front clearance 55-7/8"  
height 78-3/16"

Vend Capacity

150 standard bottles  
150 10 oz. King Size Bottles  
99 12 oz. King Size Bottles

Pre-Cool Capacity

33 standard bottles  
27 10 oz. King Size Bottles  
22 12 oz. King Size Bottles

Dimensions

28" x 27-7/8" x 78-3/16"

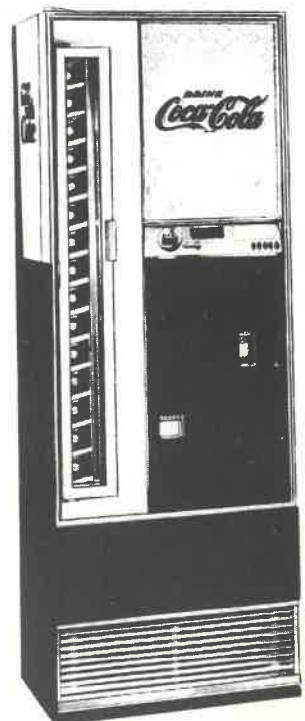

C O N T E N T S

WHAT TO DO WHEN YOU GET A NEW COOLER

set it up . . . . .	7
load the cooler . . . . .	7
check it out . . . . .	9
put it to work . . . . .	9

HOW THE VENDING MECHANISM WORKS

mechanical parts . . . . .	11
electrical parts . . . . .	14
study - vending cycle & schematic wiring diagram . . . . .	17
vending cycle . . . . .	18
schematic wiring diagram . . . . .	20
electrical circuit . . . . .	22
circuit diagram . . . . .	23

HOW TO TAKE CARE OF THE COOLER

what to clean . . . . .	24
when and what to lubricate . . . . .	24
things to adjust . . . . .	25
how to correct common vending troubles . . . . .	28

PARTS LIST . . . . .	33-2
----------------------	------

REFRIGERATION . . . . .	2-R
-------------------------	-----

TRouble CHART	28
WIRING DIAGRAM DNS-80	Page 20-A
WIRING DIAGRAM DNS-110 DNS-150	Page 21

REFRIGERATION UNIT MODEL NO.100 and 200 PAGE . . . 1-R
---



WHAT TO DO  
WHEN YOU GET A NEW COOLER

SET IT UP

KEYS

Keys are inside the coin return cup.

SERIAL NUMBER PLATE

The serial number plate is attached to the right side of the cabinet.

COIN MECHANISM

The coin mechanism may already be fastened in place.

If it is not, do this:

1. Open the access door.
2. Remove the slug rejector.
3. Line the three holes in the coin mechanism with the three screws and push the coin mechanism over the three screws. Let the coin mechanism drop down onto the screws.
4. Reinstall the slug rejector.
5. Connect the Jones Plug to the Jones Socket.

APPLICATION OF CUSTOMER INSTRUCTION PLATE

1. Clean and dry the surface of the inset in the selector panel.
2. Cut the solvent capsule with a sharp knife.
3. Spread the contents of the capsule onto the back of the plate and wait for it to become tacky.
4. Apply to the surface of the inset and press or roll firmly in place.

LOAD THE COOLER

ADJUST SHELF FOR BOTTLE LENGTH

1. Place a few bottles on the shelf and move the bottle shelf towards the front or the rear until the distance between the bottle cap and the vertical member of the vending mechanism is about 1/8" to 9/16".
2. Make sure that the adjusting pins at each end of the bottle shelf are all the way down into the mounting holes.

LOAD THE COOLER

1. Check the shelf settings.
2. Load all shelves with desired bottles.
3. Make sure that all bottles are back against the rear of the shelves.

## WHAT TO DO WHEN YOU GET A NEW COOLER

## SET UP THE SHELVES FOR BOTTLE DIAMETER

For bottle diameter there are three hole settings on the vertical member.

1. The upper hole is for small diameter bottles.
2. The middle hole is for medium diameter bottles.
3. The lower hole is for large diameter bottles.
4. To set the shelf for bottle diameter remove the shelf adjusting rod and insert it in the correct hole. Make sure the adjusting rod is all the way through the matching hole at the rear of the vending mechanism.
5. Place several bottles of the desired size on each shelf and operate the vending mechanism. If more than one bottle can be removed at the same time, place the adjusting rod in the next higher hole.

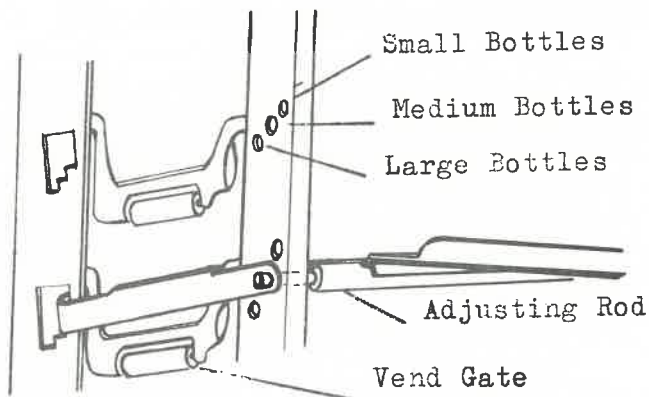

Vend  
Shelf Adjustment

WHAT TO DO WHEN YOU GET A NEW COOLER (Cont.)

CHECK IT OUT

<u>What To Do</u>	<u>What Should Happen</u>	<u>What Shouldn't Happen</u>
Plug the supply cord in, close the cooler door.	The compressor runs The condenser fan runs The evaporator fan runs. "Correct change only" window lights.	The Refrigerant lines rattle.
Put in correct change.	A bottle can be pulled from the vending mechanism	
Load the nickel tube and put a quarter into the cooler.	A bottle can be removed from the vending mechanism and correct change is returned.	
Fully load the cooler with warm bottles and let it run over night, then vend a bottle from each vend part.	The first bottle vended has a temperature of 32° to 34°F.	Some bottles are frozen or the next to be vended bottles are above the temperature of 38°F.

PUT IT TO WORK

SPACE NEEDED

Size of the working space needed around the cooler is shown on the title page of this manual. DO NOT block the louvers at the rear of the cooler. A spacer is provided with each cooler. Install the spacer at the rear of the cooler so as to keep the cooler 3 inches from the wall to provide adequate ventilation for the condenser.

LEVEL THE COOLER

Level the cooler. When the cooler is level then the door can be opened to any position and it will not move by itself. Try it half closed, straight open and wide open before you decide that the cooler is level.

Make sure that all of the leveling screws are touching the floor.

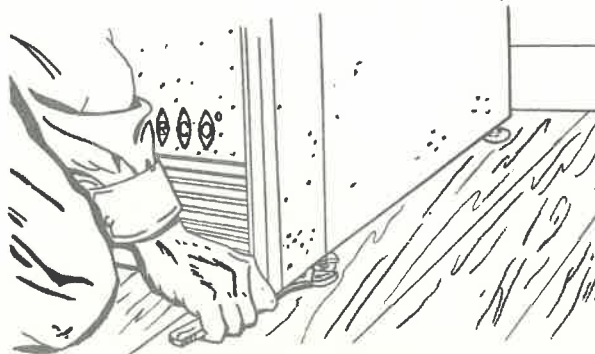

Level The Jooler

## WHAT TO DO WHEN YOU GET A NEW COOLER (Cont.)

## PUT IT TO WORK (Cont.)

## ELECTRIC POWER NEEDED

Look at the serial number plate on the right side to find out what the cooler's power needs are. Be sure that the cooler gets the right power.

The coolers use 115 volts single phase, either 50 or 60 cycle, alternating current. The voltage must never be lower than 90 or above 125.

## GROUND THE COOLER

This cooler is made with a three prong plug on the supply cord. It grounds when the plug is put into a three prong outlet. If there is no three prong outlet near the cooler use the two prong adaptor that is shipped with the cooler. If you use a two prong adaptor make sure the adaptor's ground wire is connected to a good ground.

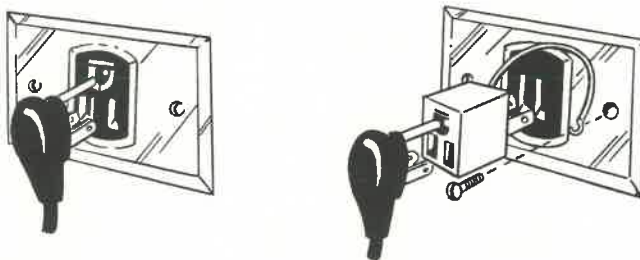

Ground The Cooler

## HOW THE VENDING MECHANISM WORKS

## MECHANICAL PARTS

## BOLT

The bolt is pivoted to the solenoid bracket by a rivet. One end of the bolt projects through a slot in the switch bar. The bolt is held in this locked position by a stud on the solenoid link. When the solenoid closes the solenoid link (along with the stud) is pulled down to unlock the switch bar.

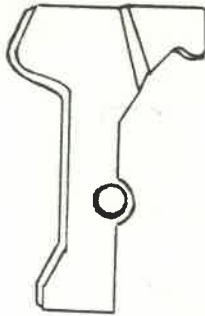

Bolt

## SOLENOID LINK

The solenoid link, mounted on the solenoid bracket, is retained by means of two rivets through slotted holes in the solenoid link. One end of the link is fastened to the solenoid. A stud on the link acts as a stop for the bolt. When the solenoid closes the solenoid link (sliding on the rivets) is pulled down to move the stud away from the bolt. When the solenoid opens, a spring pulls the link up to reposition the stud against the bolt.



Solenoid Link

HOW THE VENDING MECHANISM WORKS (Cont.)

MECHANICAL PARTS

SWITCH BAR

The switch bar is in the channel of the vending mechanism between the inner tank wall and the channel. It has a vertical slot in each end through which two studs project. A roller, top and bottom, holds the switch bar in place. The switch bar is locked in position by the bolt and the latch dog until the solenoid closes (releasing the bolt) to permit the switch bar to be moved upward. When the vend gate is moved up the cam action of roller in the left forward edge of the vend gate pushing against the slotted track lifts the switch bar up. When the bottle is removed the vend gate falls back to its original position and a spring pulls the switch bar down.

As the switch bar goes down, it works the arm of the lock switch. The normally closed contacts of the switch open in the solenoid coil circuit. At the same time the bolt locks the switch bar. The latch dog locks the bolt in place.

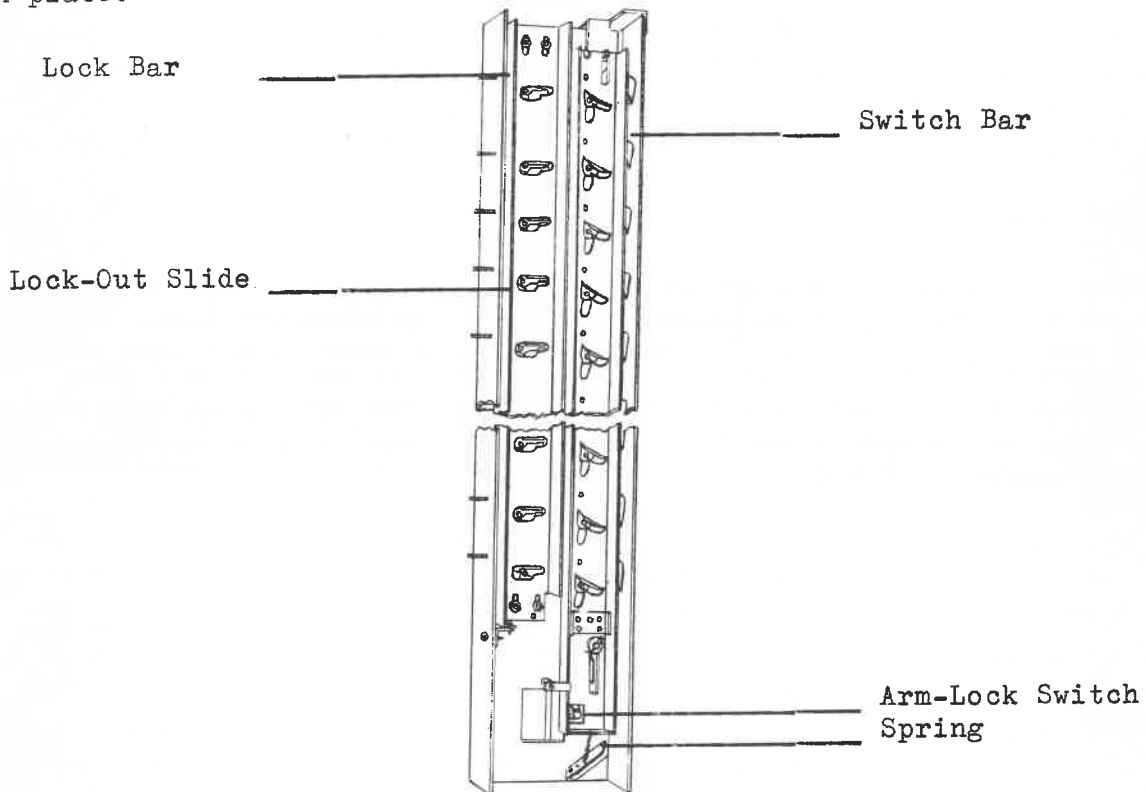

LOCK BAR

The lock bar is on the channel of the vending mechanism between the left side of the inner liner and the channel. It is held in place by four weld screws and lock nuts. The lock bar helps to retain the lock-out slides.

## HOW THE VENDING MECHANISM WORKS (Cont.)

MECHANICAL PARTS (Cont.)

## LOCK-OUT SLIDE

The lock-out slide is behind the retainer bar. Horizontally it is held in place by a channel, and vertically by a spring. When the switch bar is unlocked the bottle being removed pushes the vend gate up and the roller on the end of the vend gate pushes against the lock-out slide. At the same time, all the other lock-out slides are so positioned to block all the other vend gate rollers from moving further and prevents the removal of two bottles simultaneously.

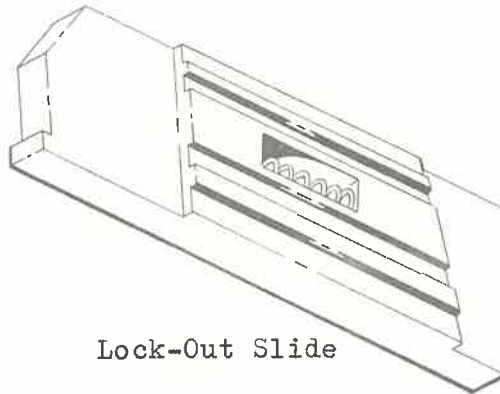

Lock-Out Slide

## FEED GATE ASSEMBLY

All of the feed gate assemblies are located at each of the vend stations. The rear end of the feed gate assembly is held in place on the channel of the vend mechanism by one rivet. The forward end of the feed gate assembly is held in place by a stud in the end of the vend gate which projects through a hole in a bracket. When a bottle is removed the vend gate moves upward and the feed gate moves down and forward.

When the feed gate is in the downward position it prevents another bottle from going into the vend station until the bottle vended is removed.

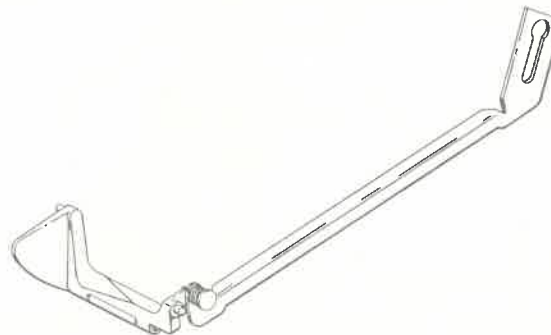

Feed Gate Assembly

## HOW THE VENDING MECHANISM WORKS (Cont.)

ELECTRICAL PARTS

## VEND SWITCH

The vend switch is below the slug rejector and is fastened to the coin changer housing with two screws and nuts. When the vend switch is down it completes the vend relay coil circuit. The normally closed vend relay switch #3 opens in the coin changer magnet circuit. When the vend switch arm rises to its original position it completes the solenoid coil circuit.

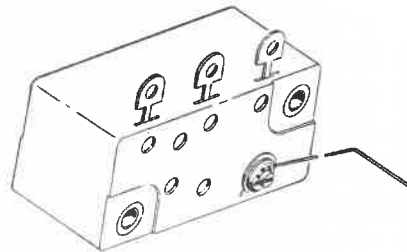

Vend Switch

## VEND RELAY

The vend relay plugs into and is located on the junction box behind the access door. The vend relay consists of three switches, two of these switches are normally open and one is normally closed. When the vend switch arm is pushed down by a coin the vend relay coil circuit is completed. That is, normally open vend relay switch #1 closes and holds the vend relay coil circuit closed. Normally closed vend relay switch #3 opens in the coin changer magnet circuit. Normally open vend relay switch #2 closes in the solenoid coil circuit.

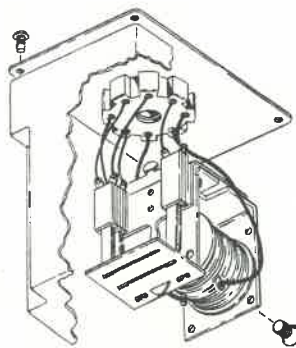

Vend Relay



## HOW THE VENDING MECHANISM WORKS (Cont.)

ELECTRICAL PARTS (Cont.)

## SOLENOID

The solenoid is near the bottom of the vending mechanism, mounted on a bracket on the front channel. It is fastened to the bracket with four screws. The solenoid closes when the normally open contact of the vend switch closes in the solenoid coil circuit. The solenoid link assembly is pulled down to unlock the switch bar.

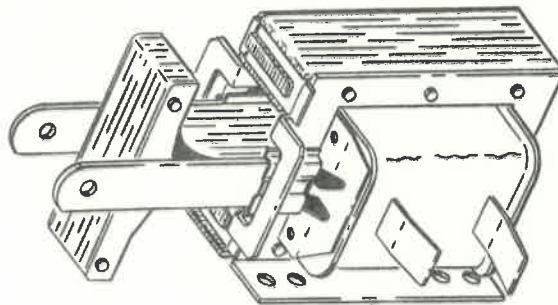

Solenoid

## LOCK SWITCH

The lock switch is near the bottom of the vending mechanism on the solenoid bracket. The switch is fastened with two screws. When a bottle is removed the vend gate rises and the cam action of the vend gate's roller lifts the switch bar. The switch bar slot by passes the switches roller arm since the roller is hinged. When the bottle is removed, the spring loaded switch bar moves downward and the edge of the slot on the switch bar strikes the switch arm roller to move the arm back. In doing this, the normally closes contact of this switch opens in the vend relay coil circuit to break this circuit.

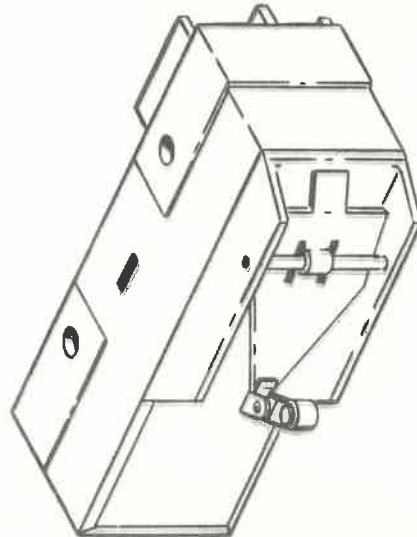

Lock Switch

## HOW THE VENDING MECHANISM WORKS (Cont.)

ELECTRICAL PARTS (Cont.)

## COIN RETURN MAGNET

The coin return magnet is fastened to the coin mechanism behind the slug rejector. Except during the vending cycle, the coin changer magnet circuit is completed. When a coin pushes the vend switch arm down and completes the vend relay coil circuit then relay switch #3 opens in the coin magnet circuit so that the blocking fingers of the coin return magnet come forward into the slug rejector to block the path of the coin so that the coin will be returned to the customer if inserted during the vending cycle.

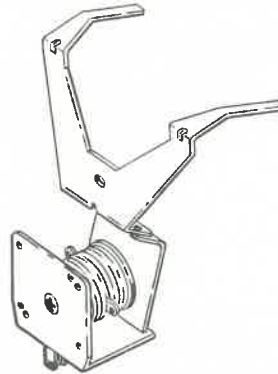

Coin Return Magnet

VENDING CYCLE AND  
STUDY - SCHEMATIC WIRING DIAGRAM

Study the written vending cycle beginning on Page 45 in connection with the schematic wiring diagram. The schematic wiring diagram can serve as an excellent "trouble shooting chart".

**Example:** Cooler accepts coin.  
Vend relay is energized but immediately "pops" out.

**Do This:** Look at Schematic Wiring Diagram  
and locate:

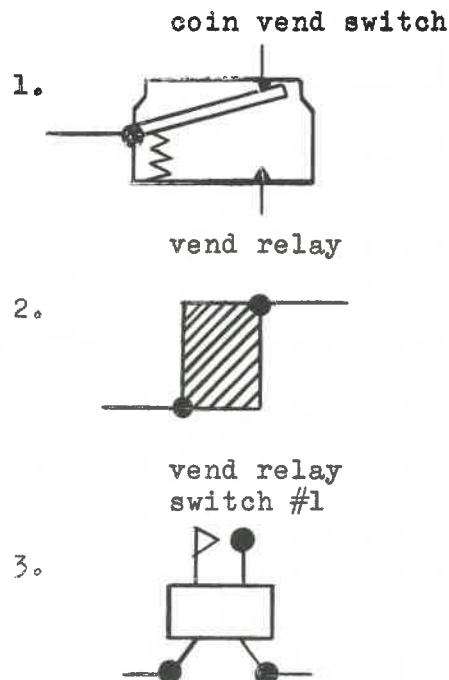

**Observations:**

1. Vend relay coil is the affected circuit.
2. N.O. coin vend switch is in the vend relay coil circuit.
3. N.O. Vend Relay Switch #1 is also in the vend relay coil circuit.
4. N.O. Vend Relay Switch #1 is the "holding switch" for this circuit.

**Conclusions:**

1. N.O. Vend Relay Switch #1 did not "hold" or keep the circuit closed.

Why?

**Check:**

1. Gap between contacts (too far apart).
2. Dirt between contacts.
3. Weak coil on Vend Relay.

## HOW THE VENDING MECHANISM WORKS (Cont.)

VEND CYCLE

WHAT DOES IT	WHAT HAPPENS
A coin	Pushes the vend switch arm down and;
The N.O. contact of the vend switch	Closes and completes the vend relay coil circuit
The Vend Relay Coil	Closes the N.O. Contact of Vend Relay Switch #1 in the vend relay coil circuit and, at the same time,
	Closes the N.O. contact of vend relay switch #2 in the Solenoid coil circuit. It also
	Opens the N.C. contact of vend relay switch #3 in the Coin Changer Magnet Circuit.
A Spring (in the vend switch)	Pulls the vend switch arm back up
The N.C. contact of the Vend Switch	Closes and completes the solenoid coil circuit
The Solenoid	Pulls the solenoid link (and the stud with it) down
The Stud	Frees the bolt, unlocking the switch bar
The Customer	Removes a bottle from the vend station
The Bottle	Lifts the Vend Gate up and forward and; at the same time,
The Vend Gate	Pulls the Feed Gate down & forward to block the next bottle.
The Lock-Out Slide Roller	Pushes the Lock-Out Slide down and, at the same time
The Lock-Out Slides	Lock out all other Vend Gate Rollers (this is the feature that prevents more than one bottle being pulled from different vend stations at one time) and, at the same time
The Vend Gate Lift	Lifts the Switch Bar and,
The Vend Gate (Spring loaded)	Snaps back to its original position and, at the same time,

## HOW THE VENDING MECHANISM WORKS (Cont.)

## \_\_VEND CYCLE\_\_ (Cont.)

## WHAT DOES IT

## WHAT HAPPENS

The Feed Gate	Moves up and to the rear to let
A Bottle	Roll into the Vending Station and at the same time
The Switch Bar (Spring loaded)	Drops back to its original position and, Pushes the Lock Switch arm down and,
The N. C. Lock Switch	Opens and breaks the Vend Relay Coil Circuit, and
The Vend Relay Coil	Opens the N.O. contact of Vend Relay Switch #1 Coil Circuit and, at the same time  Closes the N.C. contact of Vend Relay Switch #3, completing the coin changer magnet circuit  Opens the N.O. contact of Vend Relay Switch #2 in the Solenoid Coil Circuit and
The Solenoid	Opens electrically (The Solenoid arm does not move at this time) and,
The Switch Bar	Strikes the lower edge of the bolt
The Bolt	Releases the Solenoid Link
The Solenoid Link & Arm	Are pulled upward by the Solenoid Spring and
The Link's Stud	Is positioned back of the bolt to lock the bolt and, at the same time,
The Bolt	Locks the Switch Bar, and,
The Latch Dog	Locks the Bolt.

HOW THE VENDING MECHANISM WORKS (Cont.)

SCHEMATIC WIRING DIAGRAM

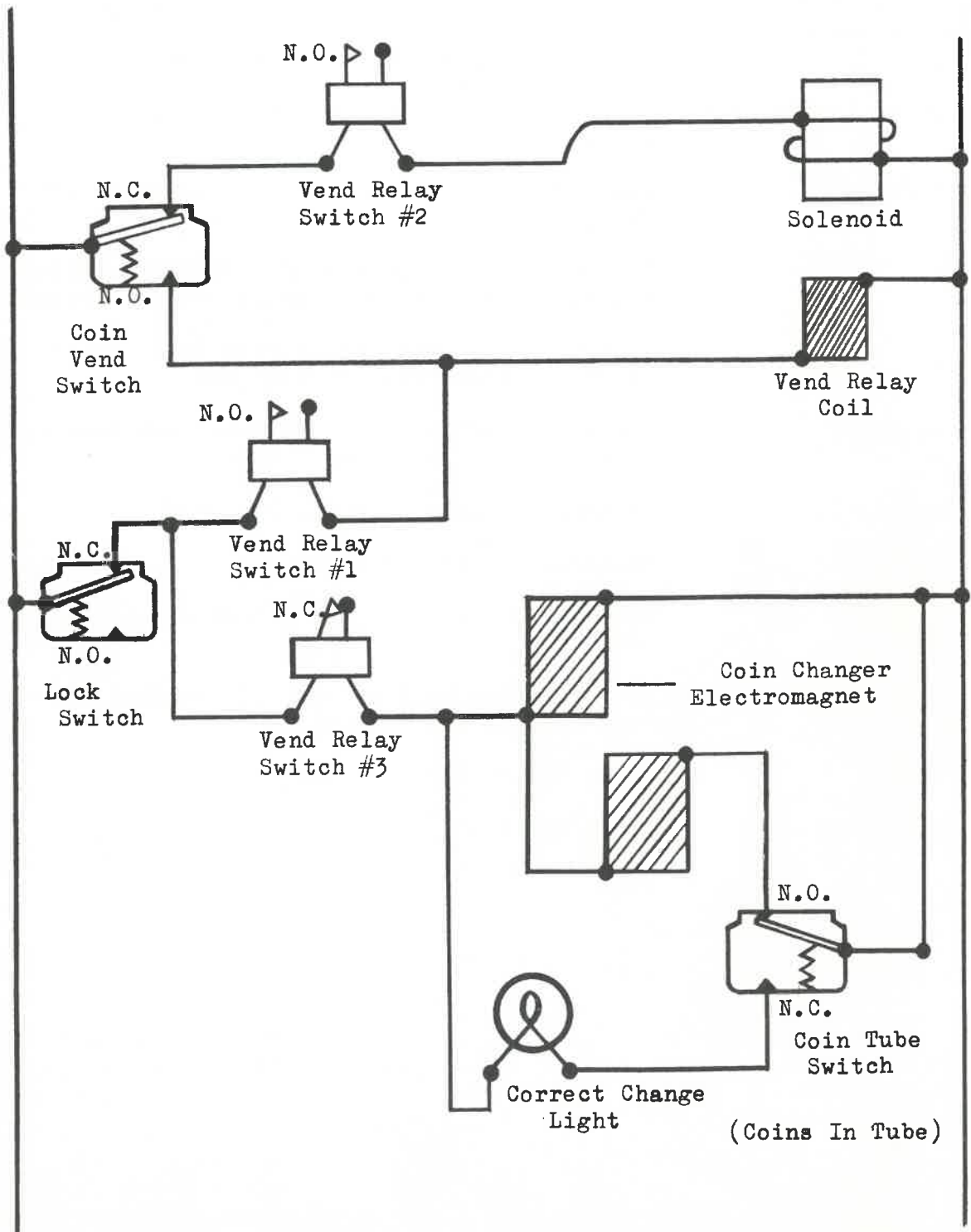

HOW THE VENDING MECHANISM WORKS (Cont.)

WIRING DIAGRAM

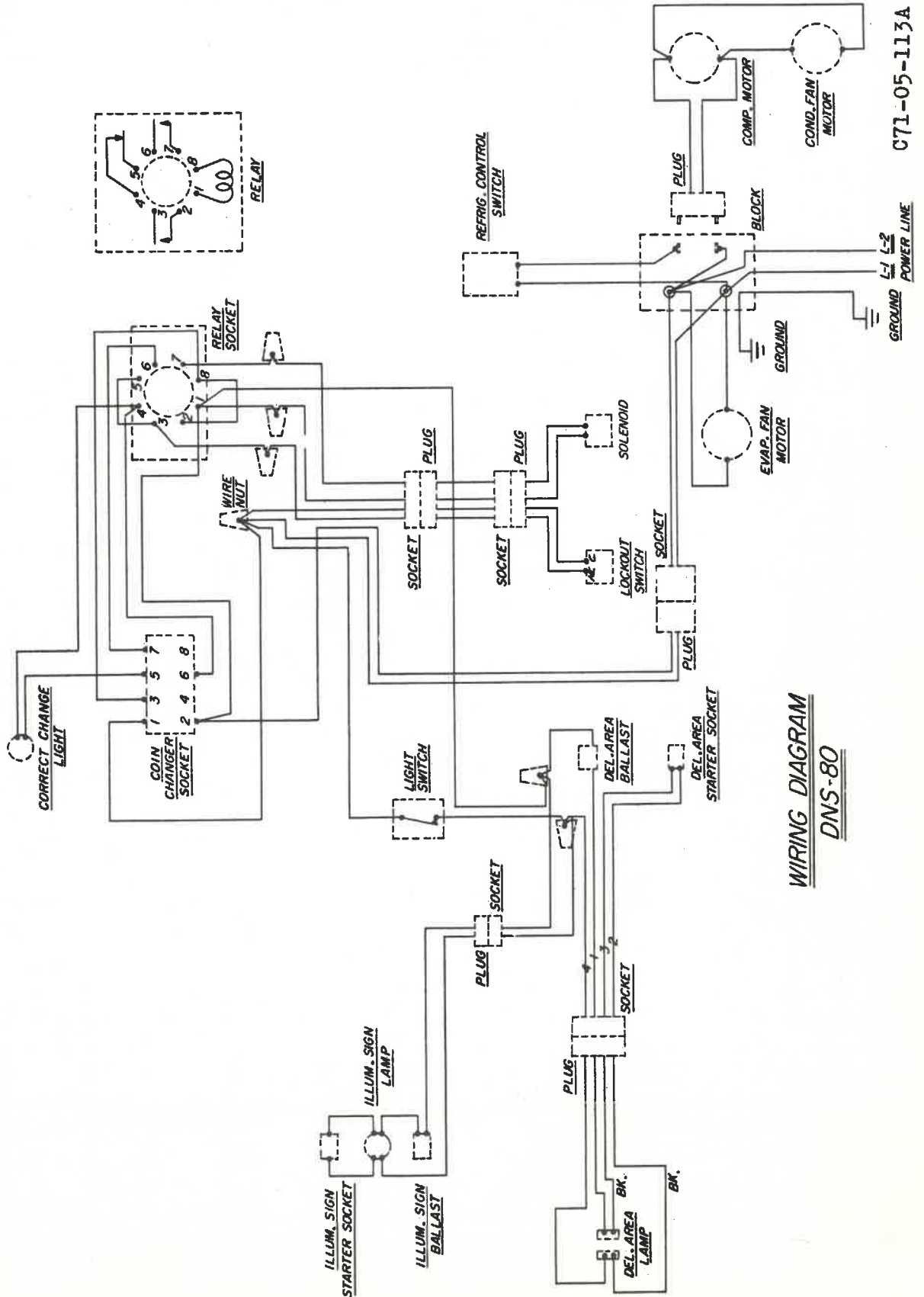

WIRING DIAGRAM  
DNS-80

C71-05-113A

GROUND L1 L2  
POWER LINE





HOW THE VENDING MECHANISM WORKS (Cont.)

WIRING DIAGRAM

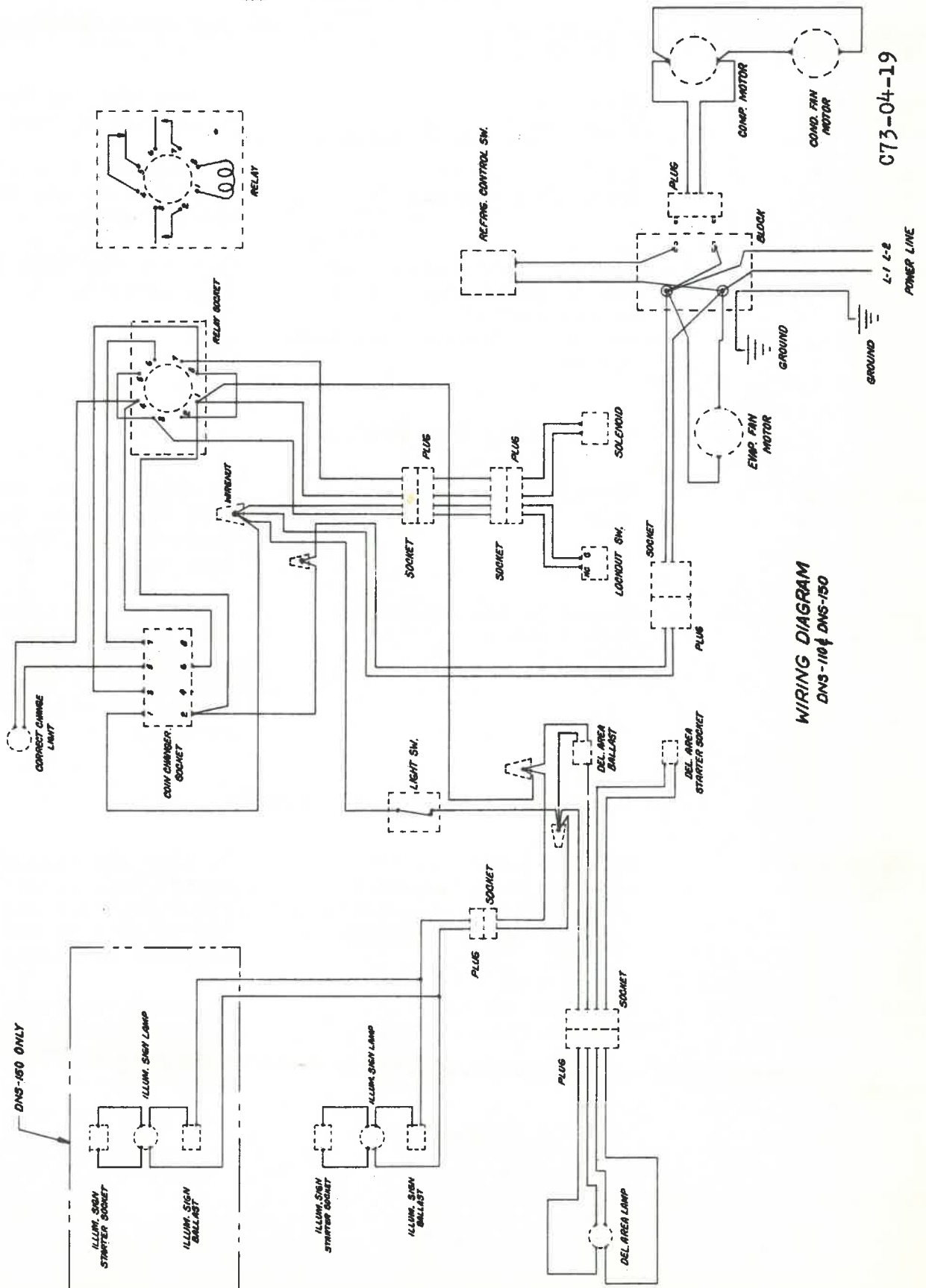

WIRING DIAGRAM  
DNS-110 & DNS-150

C73-04-19

## HOW THE VENDING MECHANISM WORKS (Cont.)

ELECTRICAL CIRCUIT

## VEND RELAY COIL CIRCUIT

SWITCHES IN THE WIRING	WHAT THE SWITCHES DO	WHY THE SWITCHES ACT
Vend Switch C. and N.O.	Closes in the Vend Relay Coil Circuit	To complete the Vend Relay Coil Circuit
Vend Relay Switch #1 C. and N.O.	Closes in the Vend Relay Coil Circuit	To keep the Vend Relay turned on during the vending cycle.
Lock Switch N.C.	Remains closed until its arm is pushed down by the switch bar (after the bottle is removed) and then it opens	To break the Vend Relay Coil Circuit.

## SOLENOID COIL CIRCUIT

Vend Switch C. and N.C.	Closes in the Solenoid Coil Circuit	To complete the Solenoid Coil Circuit so that the Solenoid will unlock the lock bar.
Vend Relay Switch #2 C. and N.O.	Closes in the Solenoid Coil Circuit	To set up the Solenoid Coil Circuit until the N.C. side of the vend switch closes and completes the solenoid circuit.

## COIN CHANGER ELECTROMAGNET CIRCUIT

Lock Switch C. and N.C.	Remains closed in the changer magnet circuit until its arm is pulled down by the switch bar	To keep the changer magnet coil circuit open until the switch bar returns to its original position.
Vend Relay Switch #3 C. and N.C.	Opens in the Coin Changer Magnet Circuit	To break the Coin Changer Magnet Circuit during the Vend- ind cycle.

CIRCUIT DIAGRAMS

VEND RELAY COIL CIRCUIT

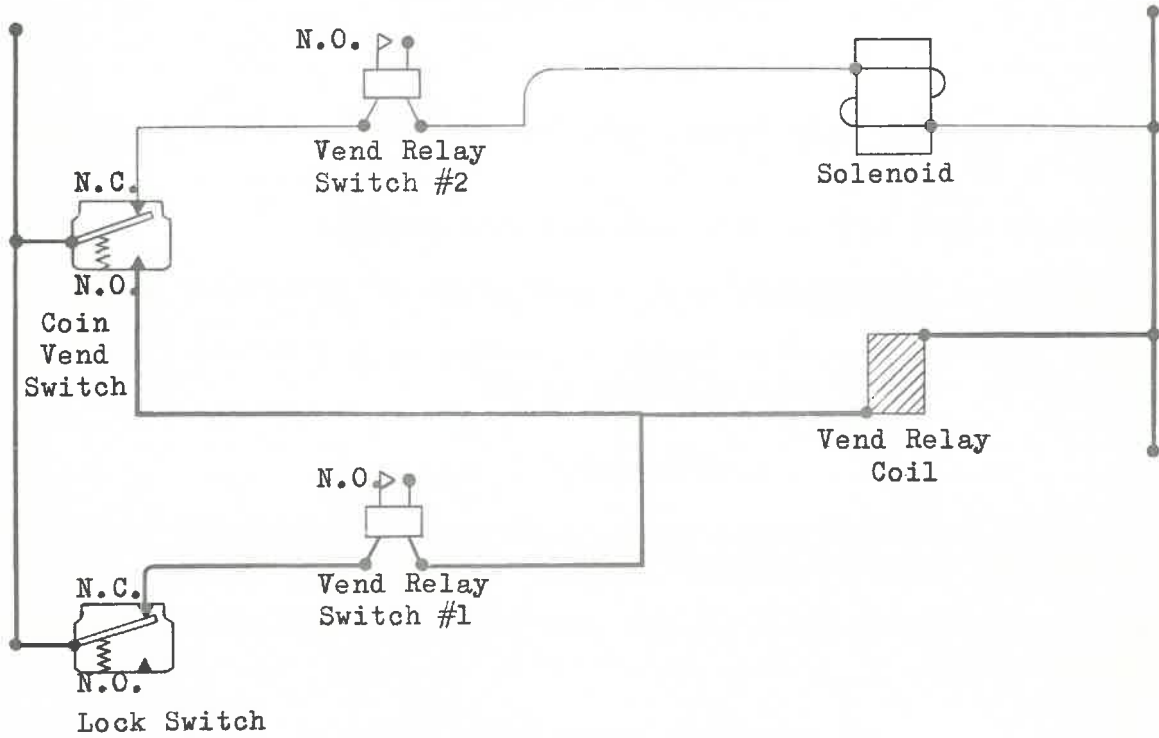

SOLENOID COIL CIRCUIT

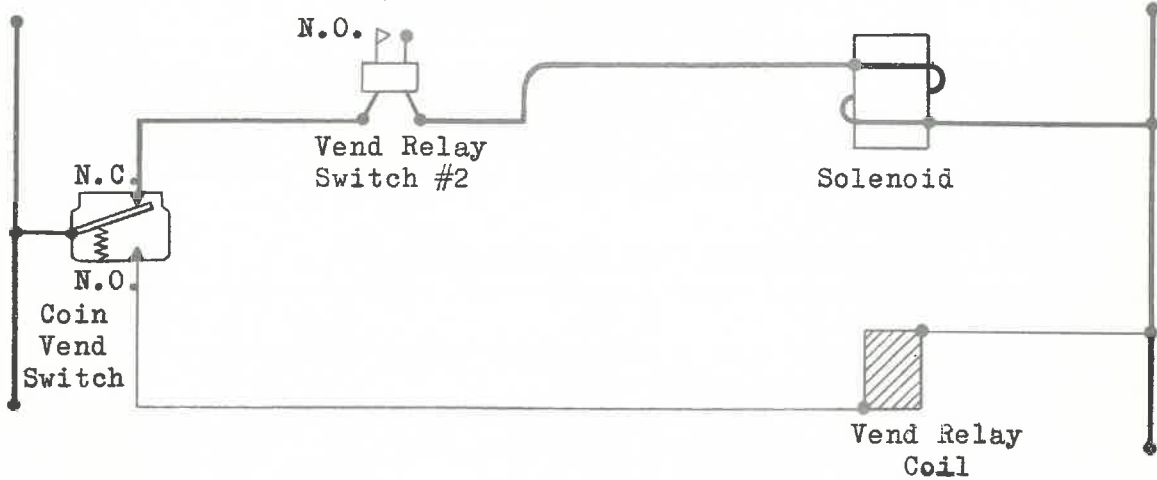

COIN CHANGER ELECTROMAGNET CIRCUIT

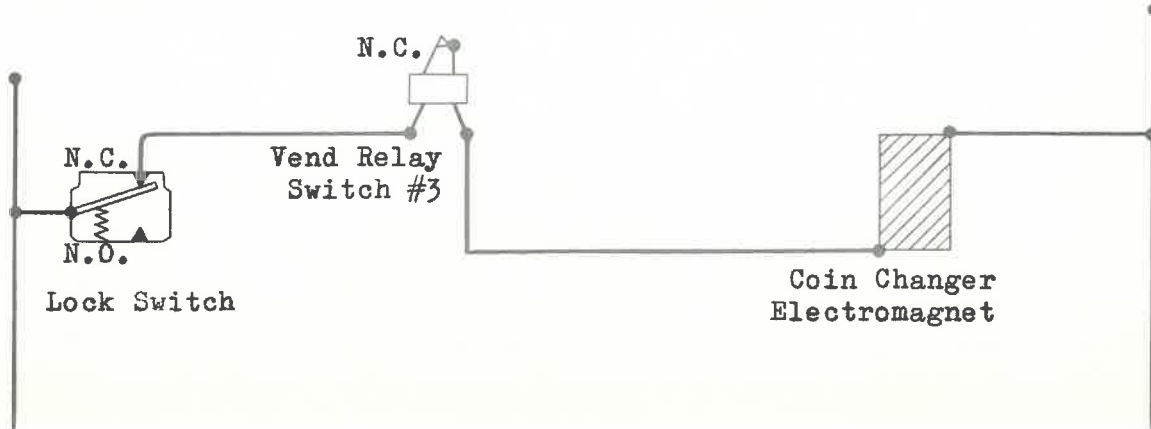

## HOW TO TAKE CARE OF THE COOLER

WHAT TO CLEAN

## CABINET

Wash the cooler exterior with either soap and warm water or a good detergent and warm water.

Wash all plastic parts with a mild soap and warm water.

The cooler should be waxed often with a good grade of automobile wax.

Any corrosion inside the cooler should be removed with fine steel wool and the area should be painted with aluminum paint.

## SLUG REJECTOR

Use a clean cloth to remove loose dirt. A dirty rejector should be cleaned with hot water and a good detergent. Dry it with a clean cloth.

Lubricate only the moving parts of the slug rejector. Oil should not be used on these moving parts.

## CHANGE THESE PARTS EVERY MONTH

PART	TO REPLACE THE PART
Slug Rejector	Loosen the two screws that lock the slug rejector in place. Lift the latches, tilt the top of the rejector towards you and pull up and out.

## WHEN AND WHAT TO LUBRICATE

HOW OFTEN	PART	LUBRICANT
Every Four months	Vending Mechanism	
	1. Bolt, edges, pivot point & side	Lubriplate 105
	2. Solenoid Link Assembly	Lubriplate 105
	3. Studs, Vend Gate	Lubriplate 105
	4. Switch Bar, at stud points	Lubriplate 105
Every Six months	5. Pivot points of Feed Gate assembly	Lubriplate 105
	1. Cam Lock Assembly for Access door	Lubriplate 105
	2. Lock Slide Assembly for Access Door	Lubriplate 105
	3. Cabinet door lift	Lubriplate 105
	4. Bearing plate for latch handle	Lubriplate 105
	5. Pivot Pin for latch handle	Lubriplate 105
Every Year	6. Latch hook on cabinet door	Lubriplate 105
	1. Door gasket, hinge side	Slipicone

H O W T O T A K E C A R E O F T H E C O O L E R (Cont.)  
\_\_THINGS TO ADJUST\_\_

TOP AND BOTTOM HINGE

To seal the gasket on the hinge side of the door, do this:

1. Loosen the three (3) hex bolts that hold the top hinge in place.
2. Loosen the hex bolt that holds the bottom hinge in place.
3. With the door all but closed, push the hinge side of the door towards the cabinet the required distance. Make sure that the distance between the door and cabinet are equal at top and bottom.
4. Tighten bolts securely in both top and bottom hinges.

DELIVERY DOOR

To seal the delivery door against the gasket, do this:

1. Loosen the screws in the hinge of the delivery door. (the screw holes are slotted horizontally)
2. Close the delivery door and push the door towards the gasket until the desired seal is obtained. Tighten the screws.
3. Exercise care so as to avoid over adjustment since this will cause a bind between the door and the gasket on the hinge side. Then the door will not seal on the open side.

LATCH STRIKE BRACKET

To adjust the gasket on the latch side of door, do this:

1. Loosen the two screws that hold the bracket to the inner tank wall.
2. Move the bracket to the rear or forward as required.
3. Tighten the screws securely.
4. Make sure that distance between door and cabinet are equal on both sides.

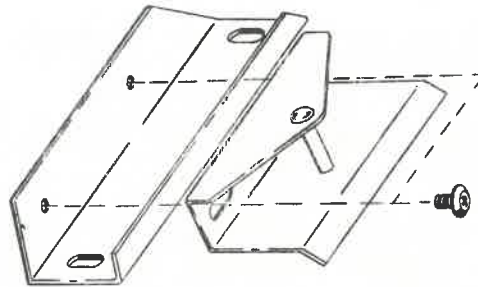

Latch Strike Bracket and Plate

LATCH STRIKE PLATE

1. Loosen the two screws that hold the strike plate to the strike bracket and move the strike plate up or down as required.
2. Tighten the screws securely.

## HOW TO TAKE CARE OF THE COOLER (Cont.)

THINGS TO ADJUST (Cont.)

## LOCK SWITCH

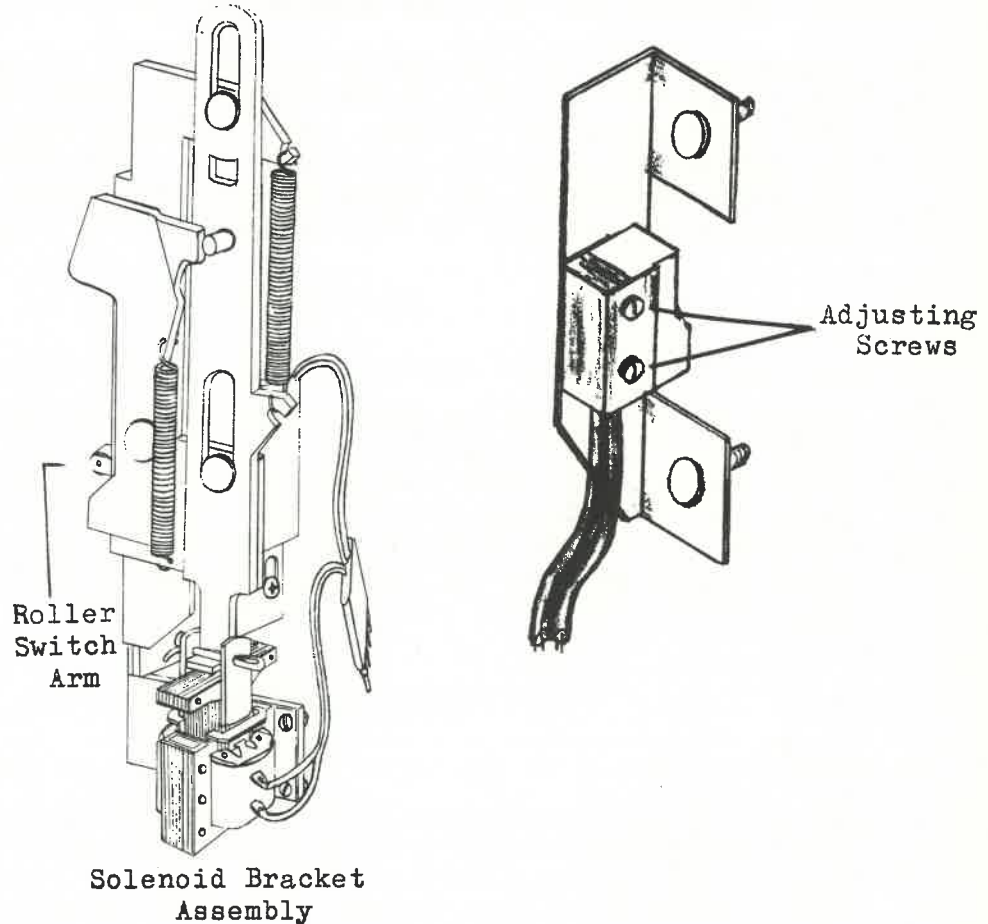

The lock switch is mounted on an adjustable bracket. Two screws secure the bracket to the solenoid bracket assembly.

To prevent jackpotting or the removal of one bottle after another when only one (1) coin has been inserted, do this:

1. Loosen the two (2) adjusting screws.
2. Move the adjustable bracket downward until the trouble is corrected.
3. Retighten the screws.

To prevent completion of the vend cycle (when irregular shaped bottles are used) before the bottle is completely removed, do this:

1. Loosen the two (2) adjusting screws.
2. Move the adjustable bracket upward until the trouble is corrected.
3. Retighten the screws.

HOW TO TAKE CARE OF THE COOLER (Cont.)

\_\_THINGS TO ADJUST\_\_ (Cont.)

SWITCH BAR - SPRING TENSION

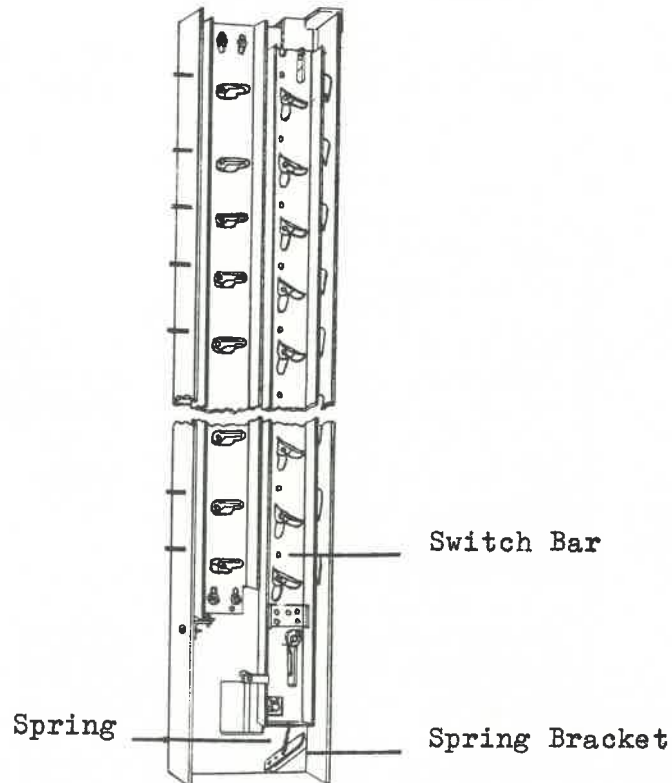

If the spring tension on the switch bar is insufficient to pull the switch bar down, do this:

1. Remove one end of the spring from the hole in the spring bracket.
2. Move the end of the spring to the next lower hole.

## HOW TO CORRECT COMMON VENDING TROUBLES

\*

REJECTS ALL GOOD COINS

A Possible Cause Is	To Make Sure	This Is What To Do
Cooler not plugged in	Look, if not	Plug cooler in
Slug rejector is neither vertical or level	Look at it and try a coin, if coin is rejected	Level the cooler
Blocking fingers remain in coin path	Remove the Slug Rejector - Unplug the cooler. Touch prods of test lamp to either side of electro magnet coil, lamp should light, if it doesn't	Put in new coil or magnet coil assembly.
The coin paths are dirty	Remove the slug rejector, look at it. If it is dirty,	Clean it with warm water, a good detergent. Dry it thoroughly.
The slug rejector is out of adjustment or the scavenger gate is not closed.	Remove the slug rejector. Put a coin in, if it rejects the coin	Adjust the slug rejector.
Low voltage	Check with a voltmeter, if voltage is low,	Correct with location outlet.
Lock Switch	Unplug cooler. Put prods of test lamp to C. and N.C. contacts. Lamp should light, if it doesn't	Put in a new lock switch
Switch #3 contact of Vend Relay	If contact is not touching	Adjust contact for "no gap" and clean contact with "Cobehn".
Switch Bar is stuck in up position	Look to see what is causing bar to stick	Repair.

\*Disconnect Electrical Plug - - Use Battery Tester.



HOW TO CORRECT COMMON VENDING TROUBLES

\* ACCEPTS COINS BUT DOES NOT LET A BOTTLE VEND

A Possible Cause Is	To Make Sure	This Is What To Do
Vend Switch	<p>Put the prods of a test lamp to N.C. and C. contacts, lamp should light, if it doesn't</p> <p>Put the prods of a test lamp to N.O. and C. contacts. Push the Switch arm down, lamp should light, if it doesn't</p>	<p>Put in a new Vend Switch</p> <p>Put in a new Vend Switch</p>
Vend Relay Coil	<p>Put the prods of a test lamp to either side of the coil. Lamp should light, if it doesn't</p>	<p>Put in a new Vend Relay or Coil</p>
Switch #1 contact of Vend Relay or Switch #2 contact of Vend Relay	<p>Put a coin in the cooler. If contact does not touch or if it touches and then opens,</p>	<p>Adjust contact to correct gap or clean contact with "Cobehn"</p>
Solenoid will not operate	<p>Unplug the cooler. Put prods of test lamp to either side of the coil, lamp should light, if it doesn't,</p>	<p>Put on a new solenoid.</p>
Solenoid Link Assembly Loose or broken	<p>Look at it, and if it is,</p>	<p>Repair or put in new Solenoid link assembly.</p>
<p><b>MORE THAN ONE BOTTLE VENDED FOR ONE SALE</b></p>		
Solenoid sticks mechanically	<p>Look, and if it is stuck,</p>	<p>Correct the bind in the Solenoid link assembly or replace the solenoid.</p>
Solenoid Spring loose or broken	<p>Look, and if it is</p>	<p>Repair or replace the spring.</p>
Solenoid remains closed after the lock switch has opened to break the Vend Relay Coil Circuit	<p>Look at Vend Relay Switch #2. Contact should be open, if it isn't,</p>	<p>Open the contact and clean with "Cobehn" or replace the Vend Relay.</p>

\* Disconnect Electrical Plug - - Use Battery Tester.

HOW TO CORRECT COMMON VENDING TROUBLES

\* MORE THAN ONE BOTTLE VENDED FOR ONE SALE (Cont.)

A Possible Cause Is	To Make Sure	This Is What To Do
<p>Vend Relay Coil Circuit stays on after the lock switch arm has been pushed down by the Switch Bar.</p> <p>Lock Switch Roller is broken</p> <p>The Shelf is not adjusted for the size of the bottles being vended</p>	<p>Unplug the cooler. Put the prods of a test lamp to C. and N.O. Push the switch arm down, lamp should not light, if it does</p> <p>Look at Vend Relay Switch #1. If the contact is stuck closed,</p> <p>Look, and if it is</p> <p>Lift the vend gate upward. If the bottle rolls under the feed gate into the vend station,</p>	<p>Put in a new lock switch</p> <p>Open the contact and clean with "Cobehn" or replace the Vend Relay</p> <p>Replace the Switch Arm or the Lock Switch</p> <p>Reset the shelf for the correct bottle diameter.</p>

\* Disconnect Electrical Plug - - Use Battery Tester.

HOW TO CORRECT COMMON VENDING TROUBLES  
 HOW TO PUT IN NEW PARTS  
 CABINET DOOR

The Part	How It's Fastened	How It Comes Off
<u>Taking It Apart</u>		
Cabinet door	Bolts - Hinge to Cabinet	Lift Off
Delivery Door	Screws-Hinge to Cabinet Door	Drops off
Access Door	Screws - Hinge to Hinge bracket	Drops off
Bottle Opener Assembly	Wing Nuts	Pull toward you
Coin Return Cup	3 screws	Drops off
Cam Lock Assembly (Access Door)	2 Hex nuts	Pull off
Coin Insert Plate	1 wing screw and 2 studs	Pull right side towards you then pull to the right
Illuminated Sign	1 screw and 2 studs	Pull bottom towards you, then pull down.
Latch Assembly	3 screws	Pull towards you
Latch Hook	Pin	Drops off
CABINET		
Strike Plate Assembly	2 screws	Drops off
Strike Plate	2 screws	Drops off
Door Lift	2 screws	Drops off
VENDING MECHANISM ASSEMBLY		
<u>Taking It Out</u>		
Shelf Assembly	None	Lift up and pull out
Vens Shelf	Rod	Push rod towards rear, pull out
	Retainer Strip 2 screws	Remove 2 screws
	3 screws	Loosen 3 screws
		Slides off

HOW TO CORRECT COMMON VENDING TROUBLES

HOW TO PUT IN NEW PARTS

VENDING MECHANISM ASSEMBLY

The Part	How It's Fastened	How It Comes Off
<p><u>Taking It Out</u> Vending Mechanism Assembly</p>	<p>Screws hold the vending mechanism to brackets</p>	<p>Move the assembly 1 inch to the right. Lift up and pull towards you.</p>
<p><u>Taking It Apart</u></p>		
<p>Shelf Supports</p>	<p>2 screws</p>	<p>Drops off</p>
<p>Solenoid Cover</p>	<p>1 Wing screw holds cover</p>	<p>Lift up and off</p>
<p>Solenoid</p>	<p>4 screws hold it to a bracket. 1 cotter pin holds solenoid to solenoid link assembly and 2 quick disconnects</p>	<p>Pull off</p>
<p>Solenoid Bracket and Lock Switch Bracket</p>	<p>2 screws</p>	<p>Pull out</p>
<p>Lock Switch</p>	<p>2 screws hold it to Lock Switch bracket. 2 screws hold terminals to switch</p>	<p>Drops off</p>
<p>Feed Gate Assembly</p>	<p>Screws in right hand vertical frame member and a spring.</p>	<p>Move assembly to the right and pull towards you.</p>
<p>Vend Gate</p>	<p>Pivot Studs</p>	<p>Drops off</p>
<p>Retainer Bar</p>	<p>4 nuts</p>	<p>Pull towards you</p>
<p>Solenoid Spring</p>	<p>Notches</p>	<p>Pull off</p>
<p>Lock-Out Slide</p>	<p>Retainer Bar</p>	<p>Lift Out</p>
<p>Switch Bar</p>	<p>2 cotter pins and a spring</p>	<p>Pull towards you</p>
<p>Roller Link Assembly</p>	<p>Retainer Bar and Switch Bar</p>	<p>Drops off</p>

H O W T O C O R R E C T C O M M O N V E N D I N G T R O U B L E S

HOW TO PUT IN NEW PARTS

VENDING MECHANISM ASSEMBLY

PUTTING IT TOGETHER AND PUTTING IT BACK

Go through the "Taking It Apart" steps backwards to reassemble the vending mechanism. Install the vending mechanism back in the cabinet. Go through the "Taking It Out" steps backwards.



P A R T S L I S T

Contents

Cooler Door Assembly . . . . .	35
Cooler Door Assembly - Delivery Door Area . . . . .	41
Cooler Cabinet . . . . .	43
Vend-Gard Mechanism . . . . .	45
Wiring Harness . . . . .	48

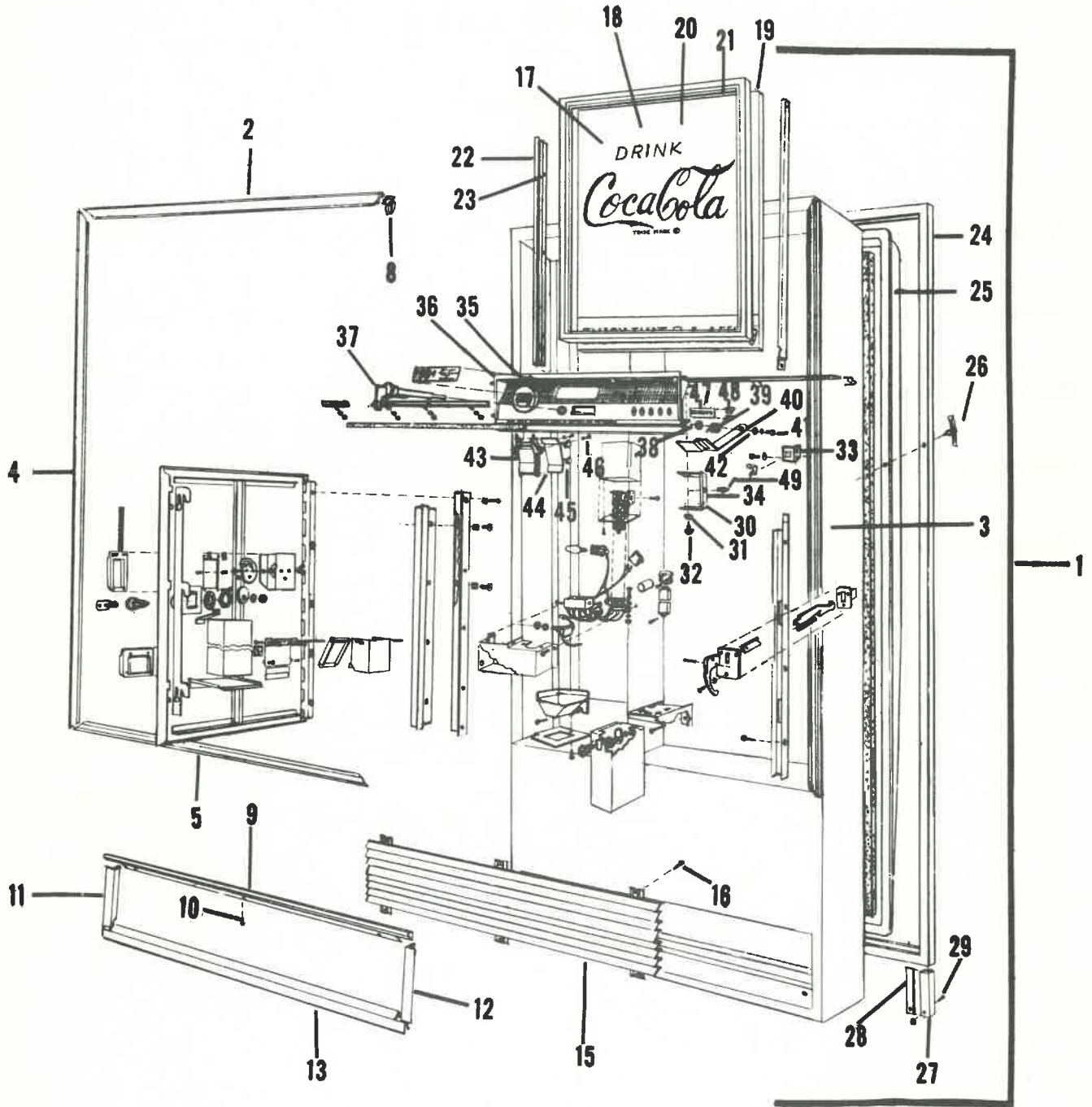

COOLER DOOR ASSEMBLY



COOLER DOOR ASSEMBLY

INDEX NO.	PART NUMBER			PART NAME AND DESCRIPTION
	DNS-80	DNS-110	DNS-150	
1	B71-05-00	F73-05-00	F74-05-00	Door, Assembly
2		BDN16-0053-1		Trim, Top, Door
3	BDN16-0053-5	BDN16-0053-6	BDN16-0053-7	Trim, Right Side
4	BDN16-0053-4	BDN16-0053-6	BDN16-0053-7	Trim, Left Side
5		BDN16-0053-1	BDN16-0053-1	Trim, Bottom
6	This Index	No. Not	Used	
7	This Index	No. Not	Used	
8		DN9-0030		Clip, Trim
9	BDN16-0081	BDN16-0056	BDN16-0056	Grill, Frame, Top
10		DN3-0016		Screw, #6 x 3/8
11		BDN16-0054-1		Grill Frame, Left
12		BDN16-0054-2		Grill Frame, Right
13		BDN16-0057		Grill Frame, Bottom
14	This Index	No. Not	Used	
15		CDN52-0040		Grill
16		DN3-0016		Screw, #6 x 3/8
17	BDN50-0040	BDN50-0040	CDN50-0041	Printed Glass
18	*C71-05-490	*C71-05-490	*C74-01-30	Mylar Insert
19	C71-05-500	C71-05-500	C74-01-20	Reflector Assembly
20	BDN50-0057-1	BDN50-0057-1	BDN50-0057-2	Clear Tempered Glass
21	BDN18-0149-1	BDN18-0149-1	BDN18-0149-2	Gasket
22	BDN16-0055-1	BDN16-0055-1	BDN16-0055-2	Sign Frame, Left Only
23		DN3-0037		Screw
24	BDN18-0081-3	BDN18-0081-1	BDN18-0081-2	Gasket, Main Door
25	DDN18-0132	DDN18-0136	DDN18-0146	Panel, Inner, Main Door
26		DN9-0041		Clip, Dart
27	**ADN18-0111	**ADN18-0138	**ADN18-0138	Filler, Gasket, Main Door
28	**A52-05-12	**A73-05-12	**A73-05-12	Retainer, For Filler Gasket
29	**	**VS6-0023	**	Screw, #8 x 1/2, Type A
30		B71-05-116		Bracket, Coin Insert Panel
31		DN7-0027		Washer, Lock
32		DN2-0029		Screw, #10 - 24
33		DN9-0053		Spring Catch
34		A71-05-117		"U" Bracket
35		D52-05-230		Coin Insert Panel Assembly
36		FDN12-0036		Coin Insert Panel - only
37		BDN12-0027		Handle, Coin Rejector
38		BDN18-0086		Bushing, Shoulder
39		ADN17-0009		Spring, Coin rejector
40		ADN13-0074		Arm, Coin return
41		DN2-0039		Screw, w/internal lockwasher, #8 - 32 x 3/8
42		DN7-0006		Washer, #10
43		CDN12-0033		Coin Chute
44		A52-05-54		Plate, Closure
45		DN9-0064		"U" Clip, Special
46		DN2-0039		Screw, w/internal lockwasher #8 - 32 x 3/8
47		ADN18-0087		Window, Corract Change
48		DN9-0064		"U" Clip, Special
49		DN9-0054		Strike

\* Can Be Used Only on: DNS-80 S/N 340-528 and higher  
 DNS-110 S/N 360-301 and higher  
 DNS-150 S/N 400-000 and higher

\*\* Discontinued using on: DNS-80 S/N 340-610  
 DNS-110 S/N 360-401  
 DNS-150 S/N 400-202

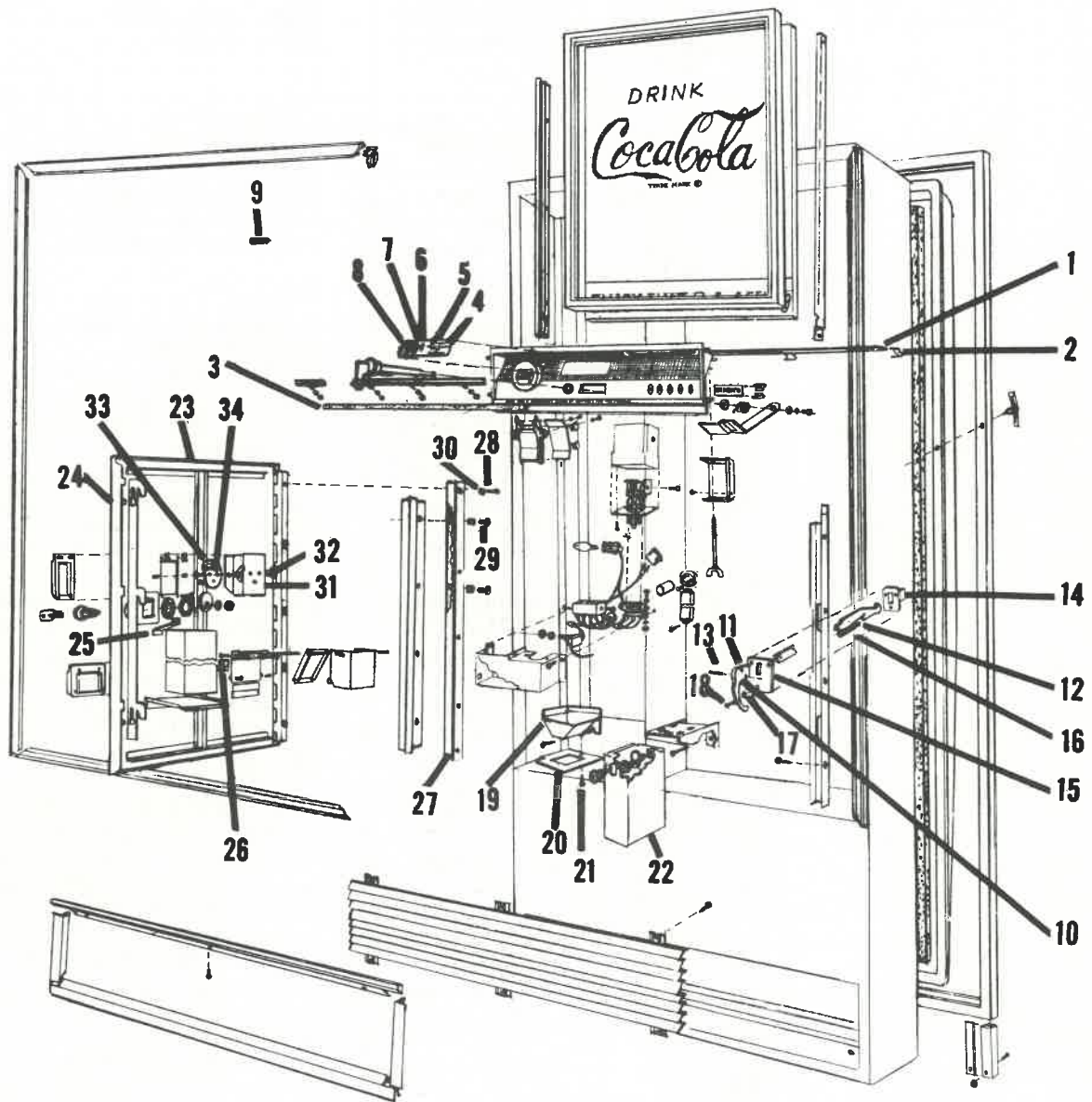

COOLER DOOR ASSEMBLY

COOLER DOOR ASSEMBLY

INDEX NO.	P A R T N U M B E R			PART NAME AND DESCRIPTION
	DNS-80	DNS-110	DNS-150	
1	- - - - -	ADN18-0109	- - - - -	Panel, Down Lighting Diffuser
2	- - - - -	DN9-0001	- - - - -	Clamp
3	- - - - -	DN36-0021	- - - - -	Sponge Tape
4	- - - - -	DDN38-0064-5	- - - - -	5¢ Instruction Sign-For Coin Changer
5	- - - - -	DDN38-0064-6	- - - - -	6¢ Instruction Sign-For Coin Changer
6	- - - - -	DDN38-0064-7	- - - - -	7¢ Instruction Sign-For Coin Changer
7	- - - - -	DDN38-0064-10	- - - - -	10¢ Instruction Sign-For Coin Changer
8	- - - - -	CDN38-0064-4	- - - - -	10¢ Instruction Sign-Channel Assy.
9	- - - - -	DN35-0010	- - - - -	Capsule, Actuator, Attach Sign
10	B71-05-310	B71-05-310	B71-05-310	Handle & Hook Assembly, Latch
11	- - - - -	BDN15-0084	- - - - -	Handle, Latch
12	- - - - -	BDN15-0045	- - - - -	Hook, Latch
13	- - - - -	DN9-0062	- - - - -	Rollpin, Latch, 1/8 dia. x 1/2
14	- - - - -	BDN18-0084	- - - - -	Latch Case
15	- - - - -	ADN15-0048	- - - - -	Bearing Plate
16	- - - - -	ADN17-0008	- - - - -	Spring
17	- - - - -	VS30-0017	- - - - -	Lockwasher, #1110
18	- - - - -	VS9-0022	- - - - -	Screw, #10-24 x 1/2
19	- - - - -	BDN12-0037	- - - - -	Hopper, Change
20	- - - - -	A52-05-58	- - - - -	Cover, Change
21	- - - - -	DN2-0039	- - - - -	Screw, #8 x 3/8 -23 W/internal Lockwasher
22	- - - - -	B52-05-80	- - - - -	Cash Box
23	D71-05-60	D73-05-60	D73-05-60	Access Door Assembly
24	- - - - -	C52-05-56	- - - - -	Access Door, Less Components
25	- - - - -	DN20-0041	- - - - -	Bumper, Rubber
26	- - - - -	DN36-0020	- - - - -	Tape, Access Door & Main Door
27	- - - - -	B52-05-44	- - - - -	Hinge Member
28	- - - - -	DN2-0010	- - - - -	Screw, Hinge to door, #10-24 x 1/2
29	- - - - -	DN2-0050	- - - - -	Screw, Hinge to support member, #10-24 x 1/4
30	- - - - -	DN7-0027	- - - - -	Lockwasher, For #10 Screw
31	- - - - -	B52-05-41	- - - - -	Housing, Crown Fuller
32	- - - - -	DN8-0027	- - - - -	Nut, Wing, #10-32 x 1-1/16
33	- - - - -	VS10-0019	- - - - -	Crown Fuller
34	- - - - -	DN3-0035	- - - - -	Screw, #10-32 x 1/2, Type F

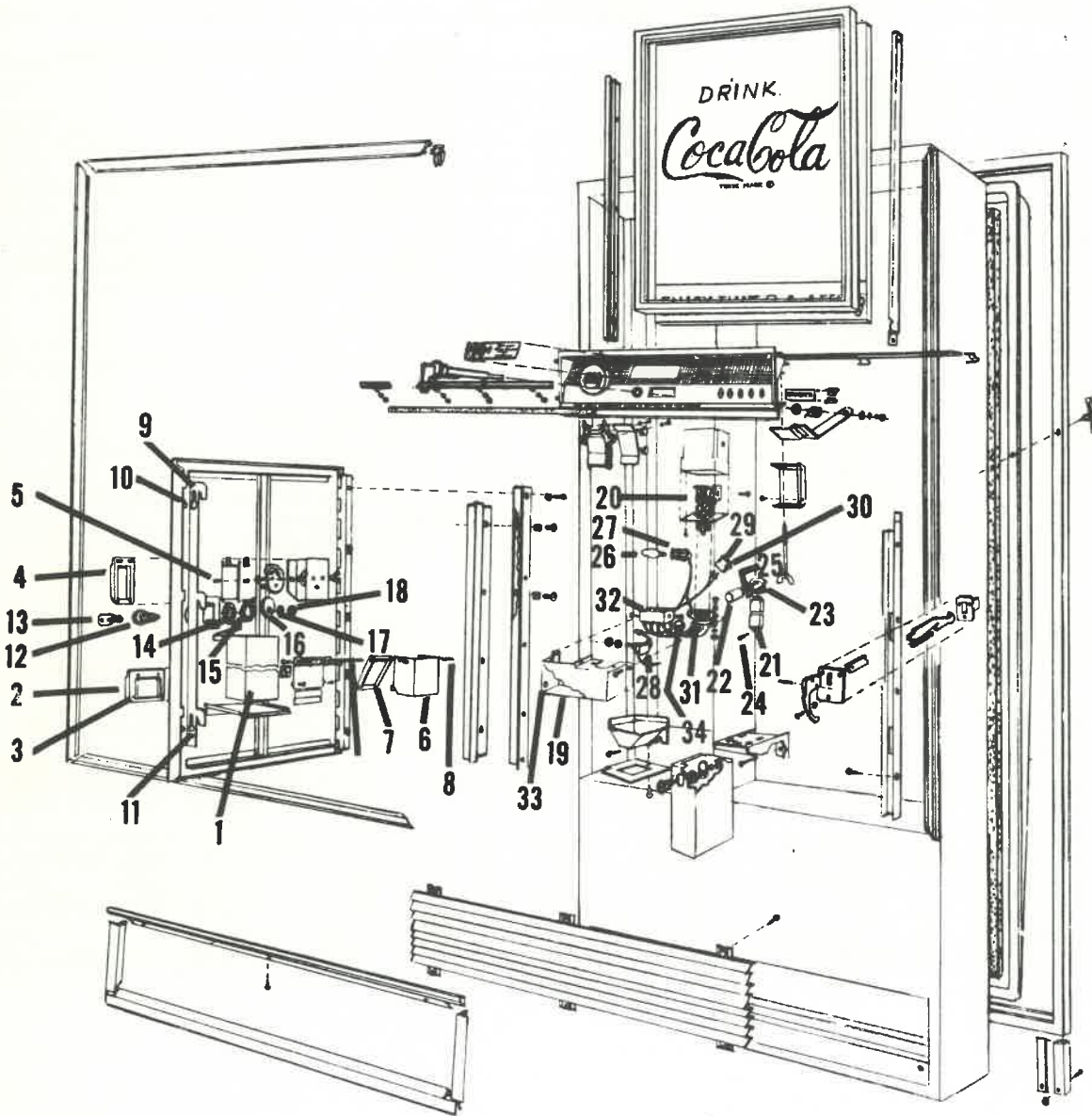

COOLER DOOR ASSEMBLY

COOLER DOOR ASSEMBLY

INDEX NO.	P A R T N U M B E R			PART NAME AND DESCRIPTION
	DNS-80	DNS-110	DNS-150	
1	B71-05-90	B52-05-90		Crown Catcher
2		DN12-0017		Change Frame, Coin Return
3		DN9-0025		Speed Nut
4		CDN12-0030		Opener Frame
5		DN3-0007		Screw, #4 x 1/4, Type Z
6		C65-12-31		Change Cup
7		A65-12-33		Door, Change Cup
8		ADN5-0077		Pin, Hinge, for door
9		B52-05-190		Lock Bar, W/cam and button
10		DN19-0040		Slide Button
11		ADN11-0019		Rivet, Shoulder
12		ADN15-0040		Lock With Keys
13		DN-6		Key
14		DN7-0016		Lockwasher
15		ADN15-0050-1		Nut Hex, Lock barrel retainer
16		ADN18-0083		Cam
17		DN7-0016		Lockwasher
18		ADN15-0040-3		Nut Hex, Cam Retainer
19	C71-05-290	C52-05-290		Wiring Box Assembly - Complete
20		DN42-0006		Relay, Vending mechanism
21	DN44-0003	DN44-0006		Ballast
22	DN48-0006	DN48-0025		Starter
23		DN49-0071		Socket, Starter
24		DN3-0037		Screw, #8 x 3/8 for Ballast
25		DN3-0014		Screw, #4 x 3/8 for Starter
				Socket
26		DN47-0003		Bulb, Change light
27		DN49-0065		Socket, With 10" leads
28		DN46-0010		Plug, Amp-Lok - 3 way
29		DN46-0013		Plug, Amp-Lok - 6 way
30		DN46-0012		Contacts, Amp-Lok
31		DN49-0070		Sockets, For Relay
32		BDN49-0003		Socket Assembly for changer. 2 leads
33		DN41-0003		Push Switch
34	VS23-0014			Wire Nut
34		DN48-0031		Wire Nut

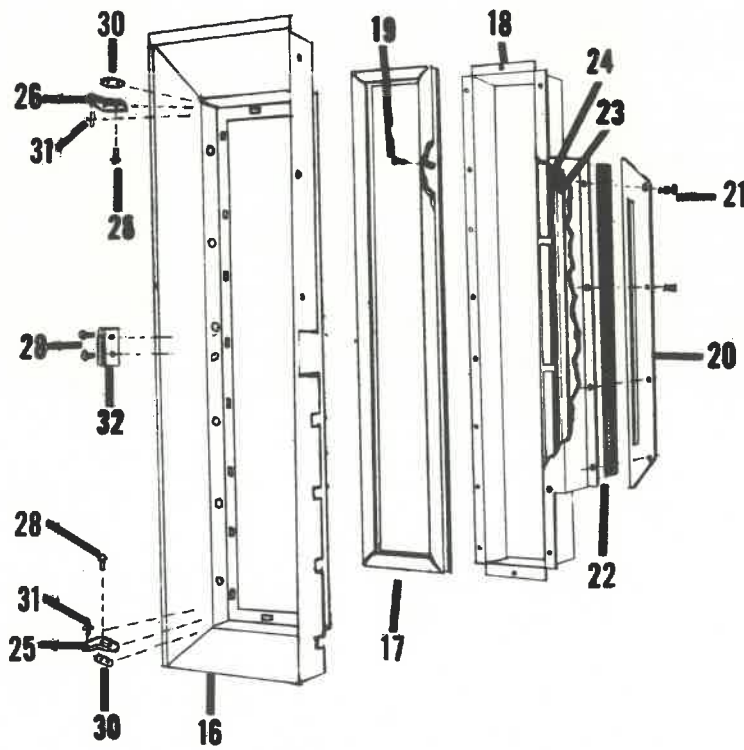
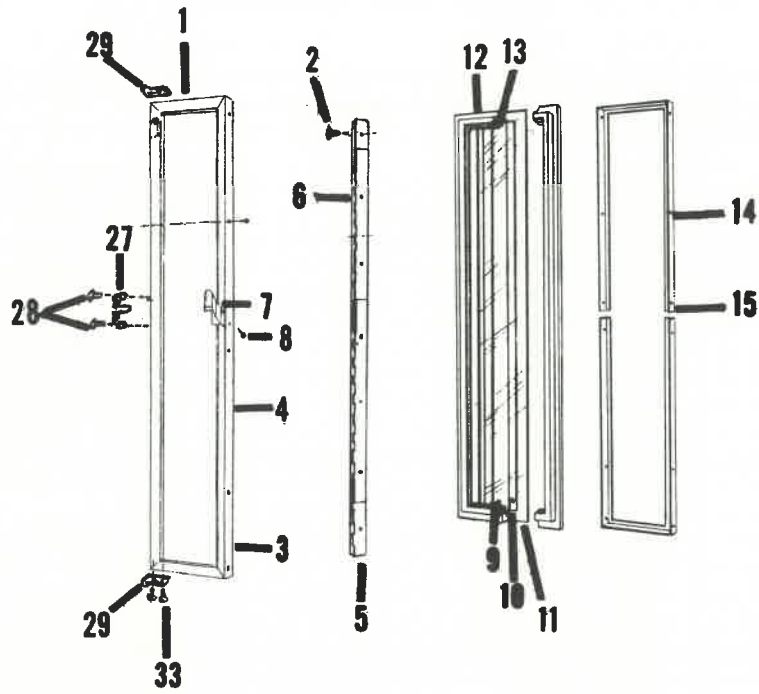

COOLER DOOR ASSEMBLY

COOLER DOOR ASSEMBLY

INDEX NO.	P A R T N U M B E R			PART NAME AND DESCRIPTION
	DNS-80	DNS-110	DNS-150	
1	C71-05-160	C73-05-160	C74-05-160	Delivery Door Assembly
2	See #2 Below			
3	C71-05-160-1	C73-05-160-1	C74-05-160-1	Delivery Door Assembly, less hinge
4	CDN52-0057	CDN52-0064	CDN52-0065	Frame, Delivery Door
5	BDN15-0044	Not Used	Not Used	Hinge, Continuous type, delivery door
2	VS9-0022	Not Used	Not Used	Screw, Hinge to delivery door, #10-24 x 1/2
6	DN2-0010	Not Used	Not Used	Screw, Hinge to delivery door, #10 - 24 x 3/8
7		ADN15-0041		Handle, Delivery Door
8		DN2-0052		Screw, Handle, #10-32 x 1/2
9	DN50-0036-7	BDN50-0036-10	BDN50-0036-13	Window Pane, Front, Less Hole
10	DN50-0036-8	BDN50-0036-11	BDN50-0036-14	Window Pane, Middle, with hole
11	DN50-0036-9	BDN50-0036-12	BDN50-0036-15	Window Pane, Rear, with hole
12	BDN18-0112-3	BDN18-0112-4	BDN18-0112-5	Gasket, Front
13	BDN18-0113-3	BDN18-0113-4	BDN18-0113-5	Gasket, Rear
14	B71-05-78	B73-05-78	B74-05-78	Retainer, Rear
15		DN3-0016		Screw, Rear retainer, #6 x 3/8
16	D71-05-510	D73-05-510	D74-05-510	Bezel, Delivery Door Area
17	BDN18-0082-3	BDN18-0082-4	BDN18-0082-5	Gasket
18	D71-05-120	D73-05-120	C74-05-120	Frame, Vend opening
19		VS6-0023		Screw, #8 x 1/2, Type A
20	B71-05-270	B52-05-270	B74-05-270	Cover, Vend Area Lamp
21		DN9-0067		Clip
22	A71-05-112	ADN18-0095	ADN18-0095	Diffuser Panel, Lamp
23	DN47-0007	DN47-0008	DN47-0008	Lamp, Fluorescent, 30 W, 36" long, #F30T8/D
24		DN49-0058		Socket, Fluorescent Lamp
25		BDN13-0117-1		Hinge Wing - Bottom - To Bezel
26		BDN13-0117-2		Hinge Wing - Top - To Bezel
27		ADN17-0025		Spring, Double Torsion
28		VS9-0022		Machine Screw, #10 - 24 x 1/2
29		ADN13-0116		Hinge Wing, Top & bottom, delivery door
30		AP-0196		Shim
31		ADN5-0080		Hinge Pin
32		BDN13-0118		Cover, Double Torsion Door Spring
33		DN2-0066		Screw, Sems, #6 - 32 x 3/8 for ADN13-0116

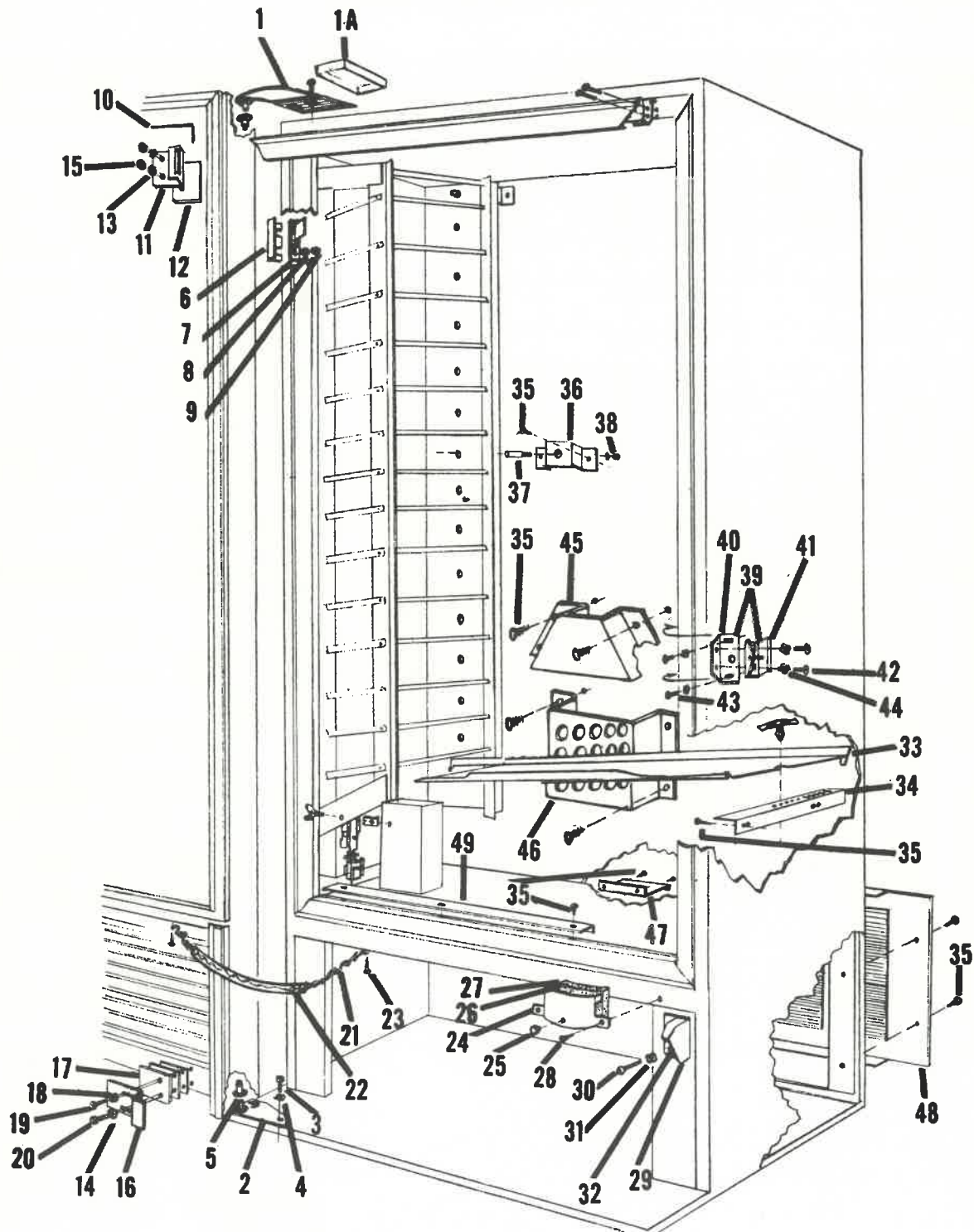

COOLER CABINET



## COOLER CABINET

INDEX NO.	P A R T N U M B E R			PART NAME AND DESCRIPTION
	DNS-80	DNS-110	DNS-150	
1		CDN12-0032		Hinge, Top
1A	B71-05-114	Not Used	Not Used	Hinge Cover Top
2		CDN12-0031		Hinge, Bottom
3		VS9-0047		Screw
4		VS30-0076		Washer
5		ADN18-0033		Bushing
6		BDN13-0073		Tab, Anti-Theft
7		BDN13-0051		Thermal Breaker, Anti-Theft Tab
8		VS30-0017		Washer, Lock #10-32
9		VS9-0096		Nut, Hex, #10-32
10		A71-05-98		Cover, Anti-Theft
11		A71-05-27		Locking Bracket
12		ADN50-0052		Spacer
13		DN7-0027		Washer, Lock, #10
14		VS30-0017		Washer, #10
15		VS28-0061		Nut, Hex
16		B52-05-22		Locking Zee
17		A52-05-21		Spacer, Locking Zee
18		DN7-0027		Washer, Lock, #10
19		DN2-0029		Screw, Indented Hex Head, #10-24x3/8
20		DN3-0032		Screw, Self Tapping, #10-24 x 5/8
21		DN15-0055		Chain, Door Stop
22		DN31-0011		Sleeve, For chain
23		DN2-0039		Screw, W/internal lockwasher, #8-24x8
24	A73-04-01	A73-04-01	A73-04-01	Seal Plate
25		DN20-0041		Bumper, Door Stop
26		DN36-0020		Sealer Tape, 1/2 x 2" x 3" long
27		DN36-0020-1		Sealer Tape, 1/2 x 2" x 4" long
28		DN2-0039		Screw, #8 - 23 x 3/8
29		A73-04-01		Door Lifter
30		DN2-0029		Screw, #10 - 24 x 3/4
31		DN7-0027		Washer, Lock #10
32		DN3-0032		Screw, Self Tapping, #10-24x5/8, type F
33	D71-07-80	D71-07-80	D71-07-80	Shelf, Feed
34	B52-03-16	B52-03-16	B52-03-16	Angle, Shelf Support
35		DN3-0037		Screw, #8 x 1/2, Type Z
36		A71-03-17		Hat Section, Support Vending Mechanism
37		ADN5-0058		Pin
38		DN8-0024		Locknut
39		B52-03-50		Latch Strike and bracket
40		B52-03-15		Bracket
41		ADN15-0047		Latch Strike
42		DN2-0050		Screw, #10 - 24 x 1/4
43		DN3-0032		Screw, Self Tapping, #10-24 x 5/8
44		DN7-0027		Washer, Lock
45	Not Used	Not Used	C52-03-13	Air Duct, Upper
46	Not Used	C59-03-01	C59-03-01	Air Duct, Lower
47		B52-02-70		Spacer, Bracket, Wall, Sub Assembly
48		BP-0130		Cover, Compressor Compartment - Accessory Part
49	A74-04-18	A74-04-18	A74-04-18	Angle, Wire Routing

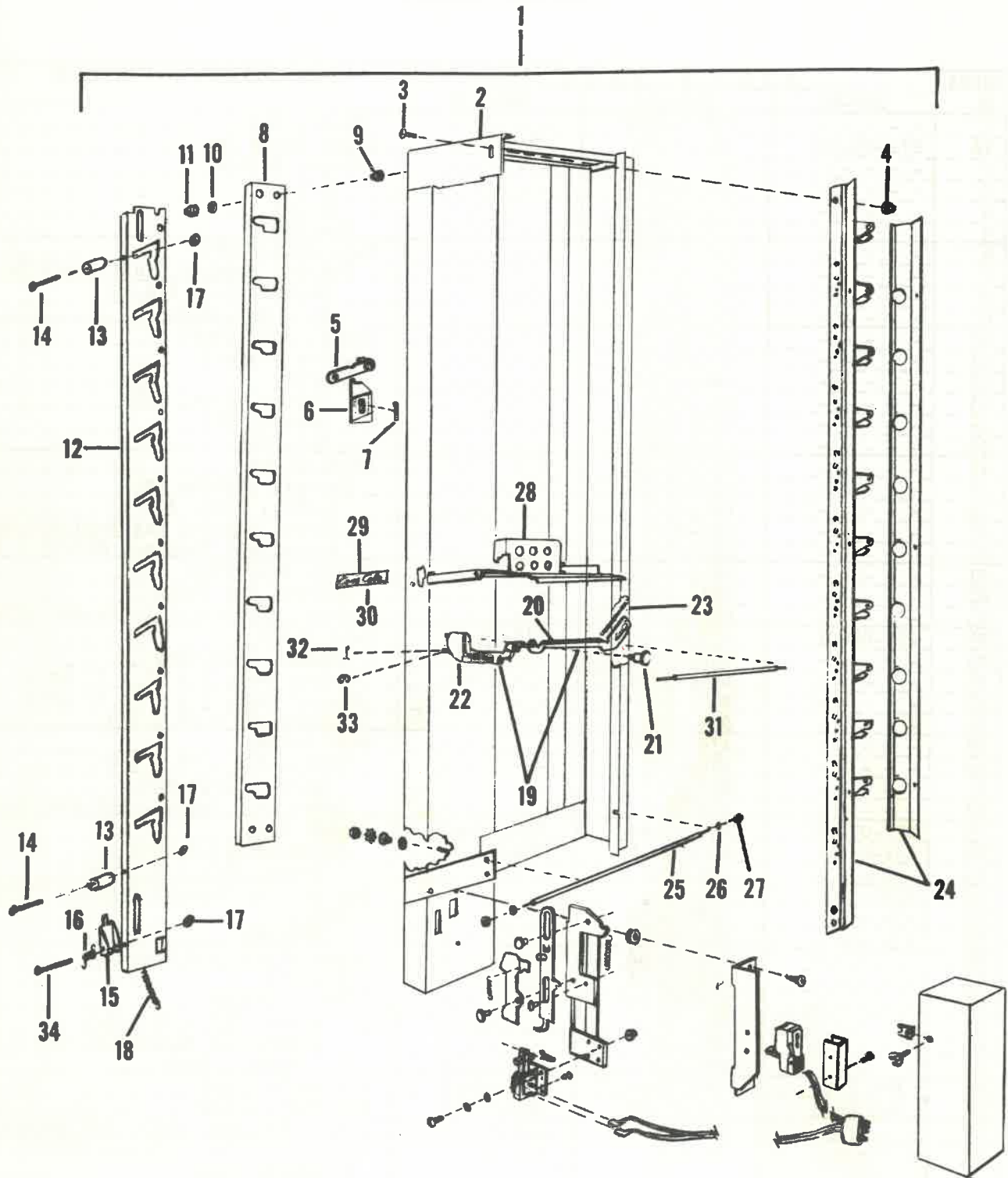

VEND-GARD MECHANISM

VEND-GARD MECHANISM

INDEX NO.	P A R T N U M B E R			PART NAME AND DESCRIPTION
	DNS-80	DNS-110	DNS-150	
1	D71-07-00	F73-07-00	F74-07-00	Vend-Gard Mechanism
2	D71-07-10	D73-07-10	D74-07-10	Frame, Sub Assembly
3		DN2-0010		Screw, #10-24 x 3/8
4		DN8-0024		Nut, Lock, #10-24
5		B52-07-30		Link, Assembly
6		BDN18-0088		Lockout Slide
7		DN17-0012		Spring, Lockout Slide
8	D71-07-13	D73-07-13	D74-07-13	Lock Bar
9		ADN18-0100		Bushing, Shoulder
10		DN7-0027		Washer, Flat
11		DN8-0024		Nut, Lock, #10-24
12	D71-07-17	D73-07-17	D74-07-17	Switch Bar
13		ADN18-0133		Roller, retainer switch bar
14		ADN5-0074		Rod Roller
15		BDN13-0114		Latch Dog
16		ADN17-0023		Torsion Spring, Latch Dog
17		DN9-0090		Retaining Ring
18		ADN17-0006		Spring
19		C52-07-50		Feed Gate & Vend Gate Sub Assembly
20		B52-07-12		Feed Gate
21		ADN11-0026		Rivet, Shoulder
22		BDN12-0035-1		Vend Gate, With Roller and Pin
23		ADN17-0006		Spring
24	D71-07-09	D73-07-09	D74-07-09	Right Hand Vertical Member
25		ADN5-0061		Spacer
26		VS30-0023		Washer, Lock, #10
27		VS28-0061		Nut, #10-24
28		C52-07-160		Vend Shelf
29		ADN38-0089-1		Coca-Cola Flavor Card
30		ADN38-0089-2		Blank Flavor Card (No Longer Used)
31		ADN5-0066		Support, Rod, Vend Shelf
32		VS29-0098		Cotter Pin
33		DN9-0096		Retaining Ring
34		ADN5-0078		Hinge Pin, Latch Dog

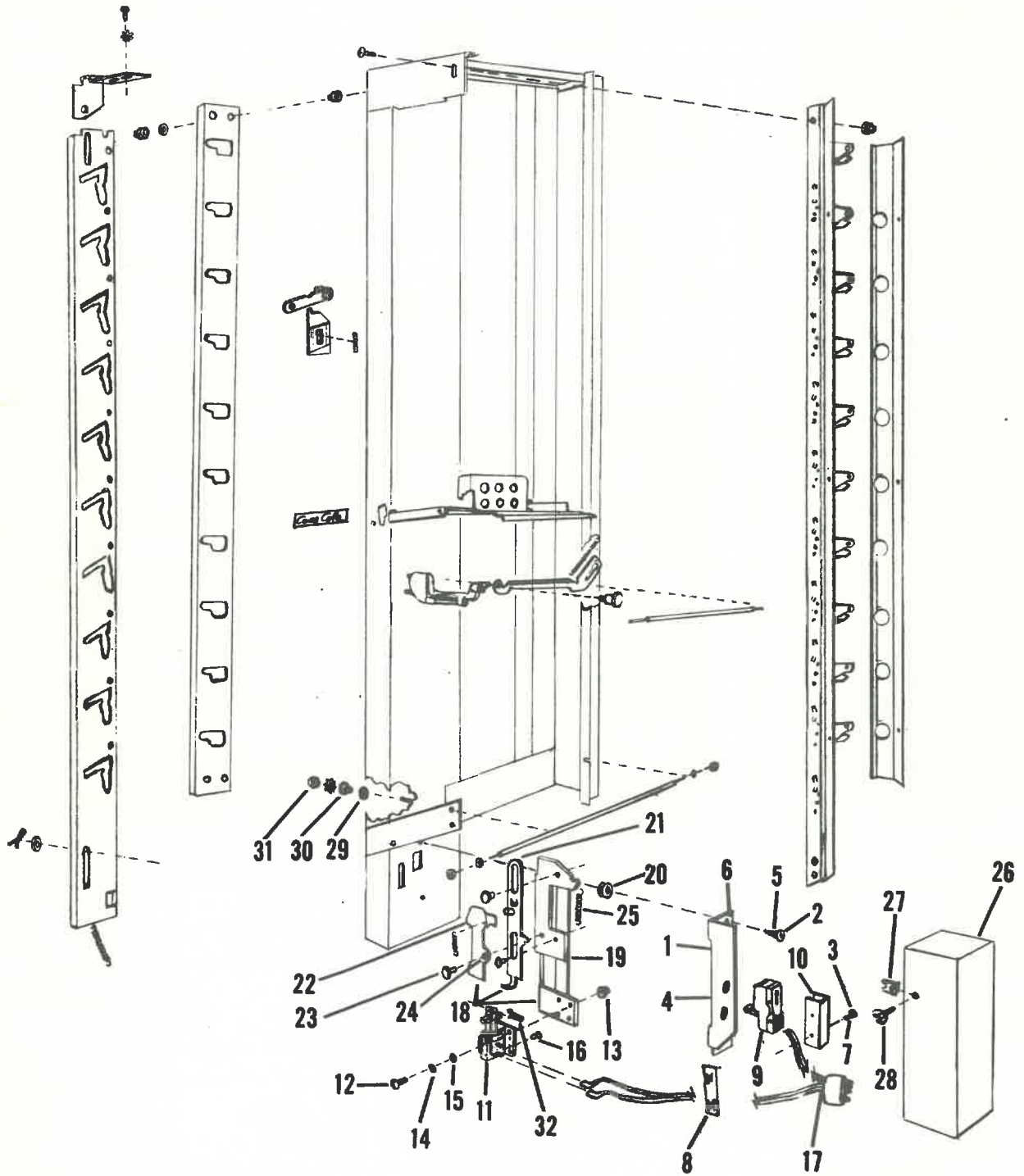

VEND-GARD MECHANISM

VEND-GARD MECHANISM

INDEX NO.	PART NUMBER			PART NAME AND DESCRIPTION
	DNS-80	DNS-110	DNS-150	
1	A52-07-39	A52-07-39	A52-07-39	Switch Bracket
2		ADN5-0071		Shoulder Screw
3		VS9-0099		Screw, #6-32 x 7/8
4	This Index	No. Not Used		
5	This Index	No. Not Used		
6		DN7-0031		Washer, Lock, #8
7		VS9-0165		Screw, #6-32 x 1
8		DN9-0072		Twin Fastener
9		DN41-0015		Switch, Lock
10		A150-00-23		Insulator
11		BDN43-0008		Solenoid
12		VS28-0125		Screw, #6-32 x 3/8
13		DN8-0017		Nut, Lock, #6
14		DN7-0013		Washer, Nylon, #6
15		DN21-0001		"O" ring
16		VS4-0110		Bumper, Rubber
17		A52-07-100		Wiring Harness, Vend-Gard Mechanism
18		B52-07-130		Latch, Sub Assembly
19		BDN13-0070		Mounting Angle
20		VS4-0109		Grommet, Rubber
21		A52-07-150		Link, Sub Assembly
22		ADN13-0067		Bolt
23		VS11-0034		Rivet, Shoulder
24		DN7-0021		Washer, Brass, #10
25		ADN17-0017		Spring
26		B52-07-120		Cover
27		DN9-0059		Clip, "U", Tinnerman
28		DN4-0017		Thumb Screw
29		DN7-0021		Washer, Flat, #10
30		DN19-0044		Bushing, Shoulder
31		DN8-0024		Nut, Lock, #10-24
32		DN9-0039		Cotter Pin, Solenoid, 1/8 x 1"

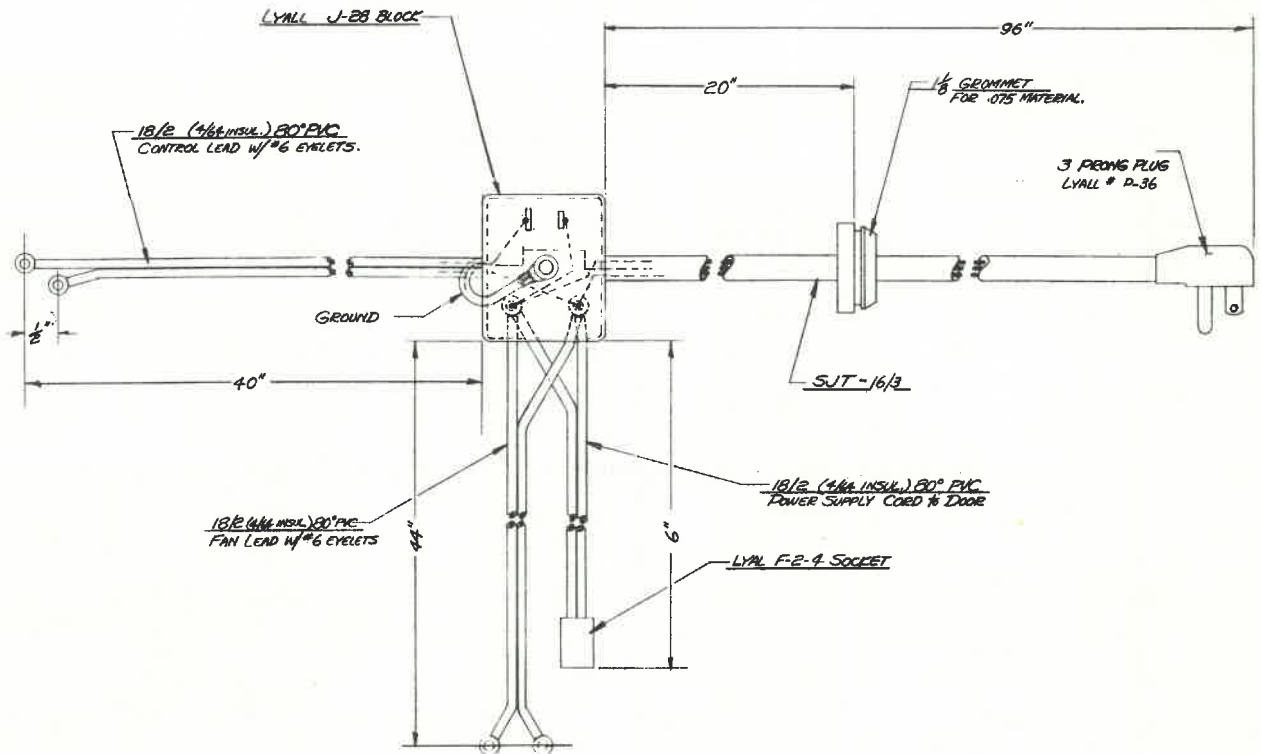

\* CDN49-0060

Main Wiring Harness

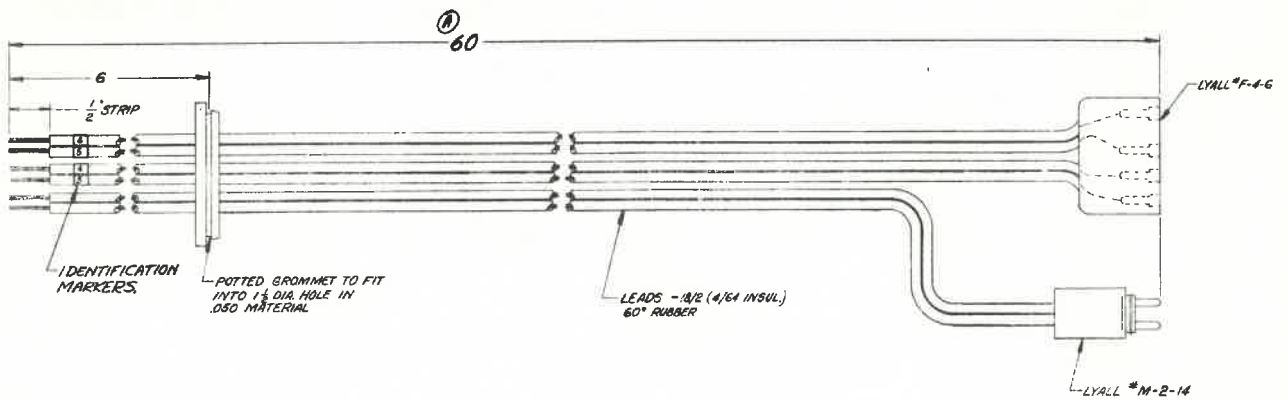

\* BDN49-0069 A

Supply Cord, Main Door to Machine Compartment

\* Order by part number indicated.

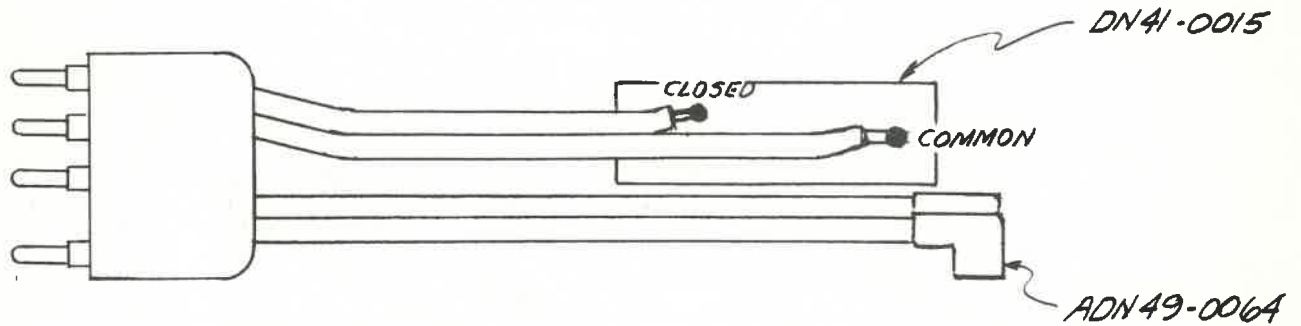

\* A52-07-100      Harness - Vending Mechanism

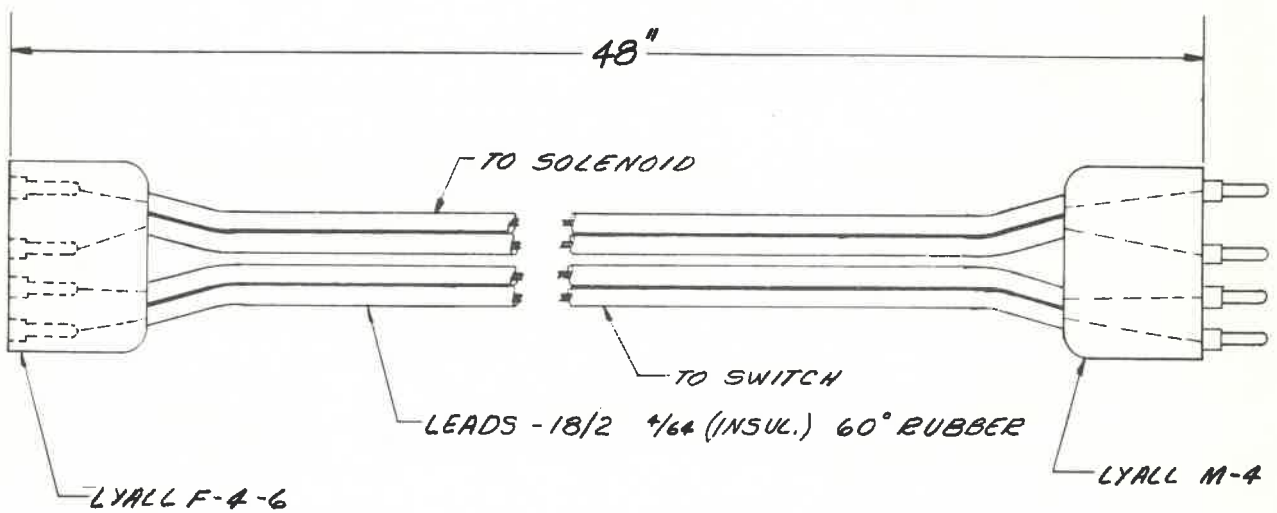

\* ADN49-0068      Jumper, Machine Compartment to Vend-Gard Mechanism

\* Order by part number indicated.

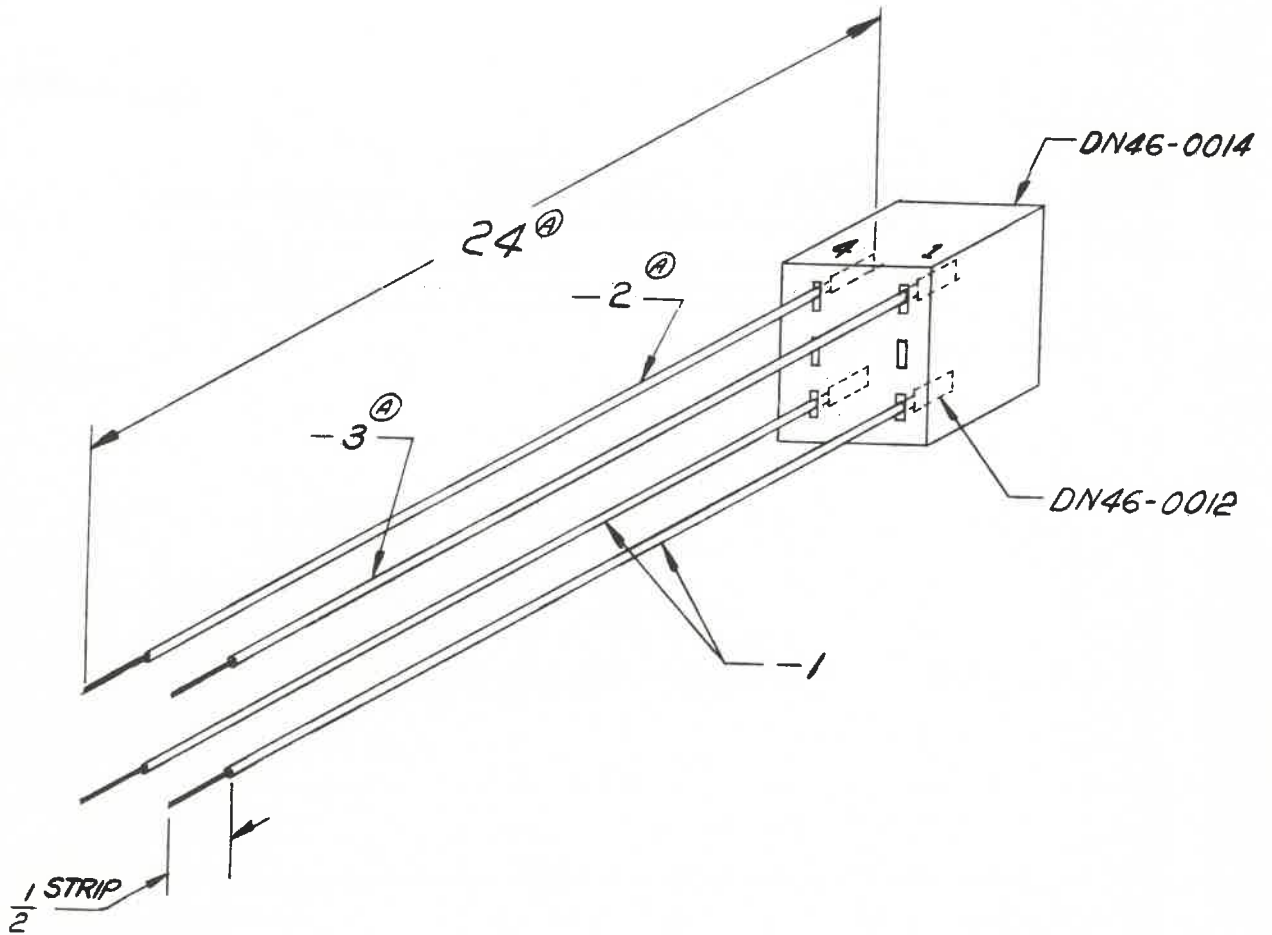

\* A52-05-260A Jumper Assembly to Delivery Area Lamp

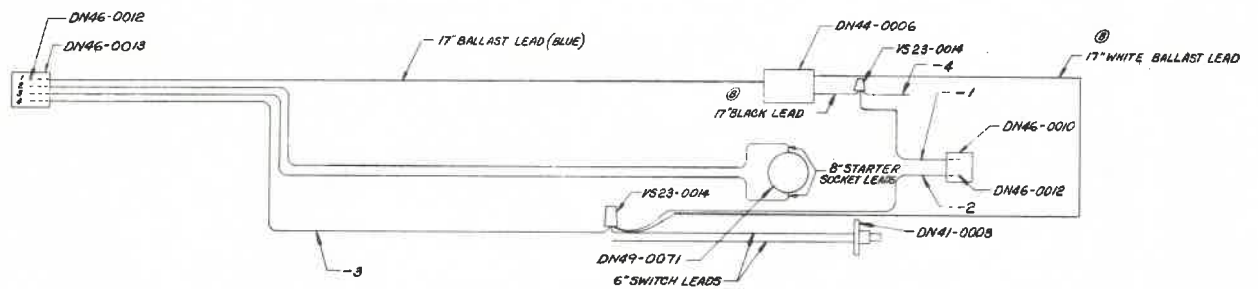

\* B52-04-90B Power Supply Harness To Fluorescent Lamps

\* Order by part number indicated.



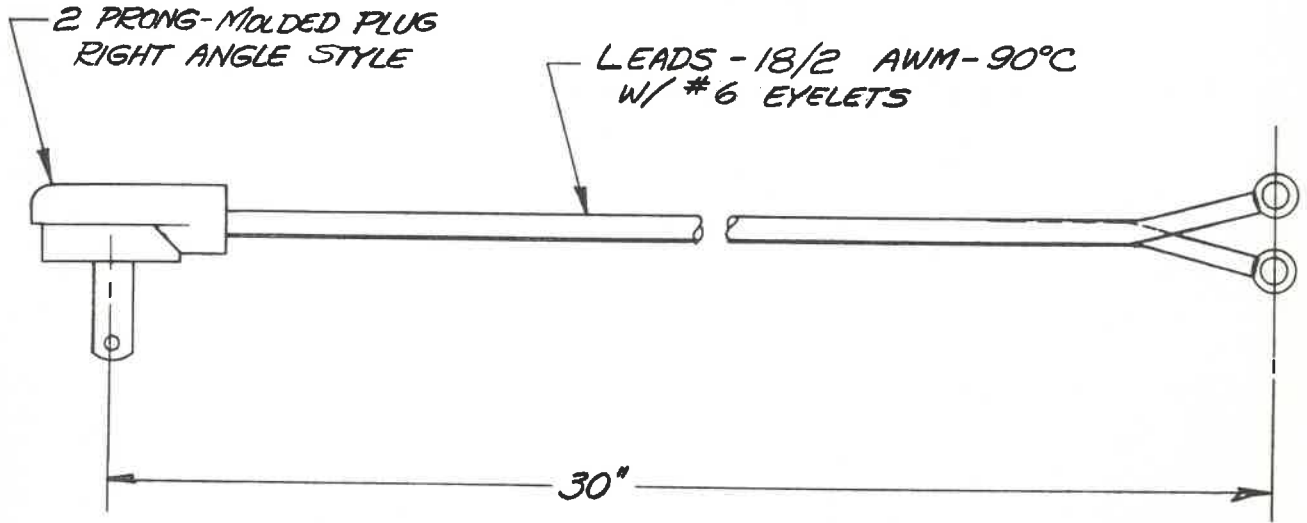

\* ADN49-0061 Compressor Lead

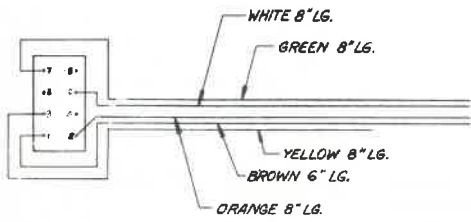
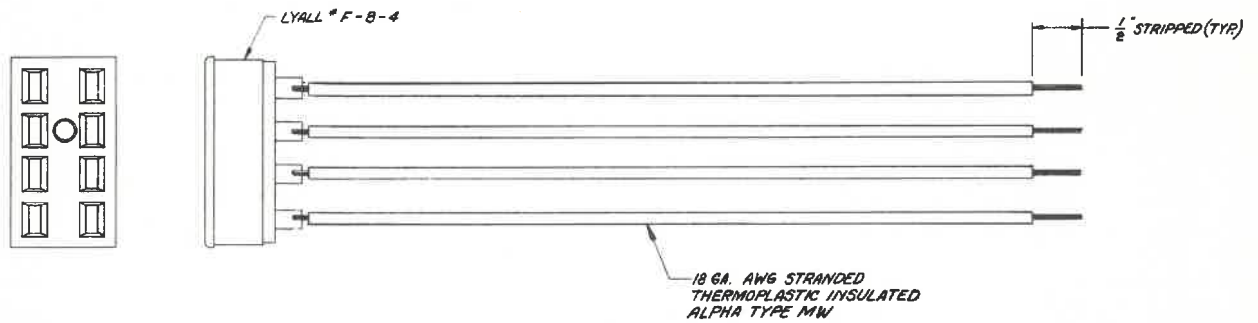

\* BDN49-0066B Socket Assembly to Coin Changer

\* Order by part number indicated.



REFRIGERATION  
UNITS

USED IN  
COOLERS

Model 200

DNS-80

Model 100

DNS-110  
&  
DNS-150

C O N T E N T S

How The Refrigeration System Works

mechanical parts	. . . . .	3-R
electrical parts	. . . . .	5-R
electrical operation	. . . . .	7-R
electrical circuits	. . . . .	10-R
circuit diagrams	. . . . .	11-R
refrigeration cycle	. . . . .	14-R

How To Take Care of The Refrigeration System

what to clean	. . . . .	16-R
when and what to lubricate	. . . . .	16-R
things to adjust	. . . . .	16-R
correcting troubles	. . . . .	18-R
how to correct common refrigeration troubles	. . . . .	19-R
wiring harness	. . . . .	28-R

Parts List	. . . . .	29-R
------------	-----------	------

TROUBLE CHARTS PG.	19-R
WIRING DIAGRAM PG.	28-R

## HOW THE REFRIGERATION SYSTEM WORKS

## MECHANICAL PARTS

## COMPRESSOR MOTOR

The compressor motor (sealed in the compressor housing) drives the compressor with a shaft that is shared by both parts.

## COMPRESSOR

The compressor (sealed in the compressor housing) sucks cold, low pressure freon gas from the evaporator and pumps hot, high pressure freon gas out to the condenser.

## CONDENSER

The condenser, located in the base of the cooler, at the front, takes heat out of the hot, high pressure gas that comes from the compressor. The gas loses heat as it goes through the condenser coils, and changes into a liquid because it is still under high pressure.

## CONDENSER FAN

The condenser fan (between the condenser and motor compressor) first sucks air from the outside of the cooler through the condenser. This air takes heat from the condenser first and then is blown over the compressor housing from which it also takes heat before going back outside of the cooler. The condenser fan runs when the motor compressor runs.

## MOLECULAR STRAINER DRYER

The molecular strainer dryer is in the liquid line between the condenser and the capillary tube. This dryer traps and holds water molecules but lets oil molecules and freon molecules go through into the capillary tube.

## CAPILLARY TUBE

The capillary tube (between the condenser and the evaporator in the refrigerant line) has a very small inside diameter, so the flow of the liquid freon from the condenser into the evaporator is slow, but steady, even with the pressure the compressor builds up in the condenser. This helps to keep the pressure in the evaporator low.

## EVAPORATOR

The evaporator (in the cooler cabinet) takes heat from the air in the cooler cabinet and gives this heat to the liquid refrigerant. The liquid refrigerant is evaporated (boiled off) as a gas, and the gas is sucked out by the compressor and so the pressure is kept low.

## HOW THE REFRIGERATION SYSTEM WORKS (Cont.)

## MECHANICAL PARTS (Cont.)

## EVAPORATOR FAN

The evaporator fan sucks warm air from around the bottles in the cooling compartment and blows it across the evaporator. As the air goes across the evaporator, it gives up heat to the evaporator, then goes back to the bottles, and takes heat from them. This fan runs all the time when the cooler is plugged in.

## CONDENSATE PAN

The condensate pan (located in the compressor compartment) collects the water which runs from the cooler during the defrost cycle. The water is evaporated into the surrounding air by means of soakers, and the refrigerant discharge line, and the air movement resulting from the condenser fan blade rotation. The soakers fastened to the discharge line, and extending down into the pan absorb the water. When the compressor is running, heat from the discharge line vaporizes the water, in the soakers, and the water vapor is carried into the air by the action of the condenser fan blade.

## HOW THE REFRIGERATION SYSTEM WORKS (Cont.)

## ELECTRICAL PARTS

## TEMPERATURE CONTROL

The temperature control is the name of a part that is made up of a control bulb connected by a small metal tube to a bellows. The control bulb is in a clip back of the evaporator. The bellows and a switch known as the temperature control switch are in the temperature control box which is fastened to the cup station bracket inside the cooler.

The control bulb and the bellows have a vapor in them. When the temperature of the vapor in the bulb rises, it builds up pressure in the bellows tube. This pushes the bellows out, making it longer. When the control bulb is cool the vapor shrinks back, and the bellows pull in and get shorter. These movements of the bellows work the switch - called the temperature control switch - closing it when the bulb is heated and opening it when the bulb is cold.

The contacts of the temperature control switch are in the compressor motor's running and starting circuits. They are also in the condenser fan motor circuit.

When the cabinet temperature gets up to the cut-on setting, the temperature control switch closes in the compressor motor's starting and running circuits and in the condenser fan circuit. When the cabinet temperature gets down to the cut-off setting, the temperature control switch opens in these circuits.

The temperature control cam is on the side of the temperature control box. The inside range screw is under the fibre cover of the temperature control box. The temperature cam may be turned with a screw driver. Turn the cam counter clockwise for warmer cut-off temperatures. If further adjustment is needed, turn the inside range screw counter clockwise for colder cut-off and cut-on temperatures and clockwise for warmer cut-off and cut-on temperatures. When the range screw is turned it changes both the cut-off and cut-on temperatures, and changes them both the same amount.

CAUTION: To adjust temperature control see Pages 16-R and 17-R  
"Things To Adjust"

## STARTING RELAY

The starting relay (in the terminal box on the side of the compressor shell) is an electromagnetic relay whose contacts are closed by the magnetic field of the relay coil, and are opened by gravity. It is made up of a relay coil and one set of contacts. The relay coil is in the running circuit of the compressor motor. The relay contacts are in the compressor motor's starting circuit and can complete or break only that circuit.

## HOW THE REFRIGERATION SYSTEM WORKS (Cont.)

## ELECTRICAL PARTS (Cont.)

## STARTING RELAY (Cont.)

When the compressor motor and the condenser fan motor first start, the starting relay closes and completes the compressor motor starting, winding circuit. After the compressor motor gets up speed, the starting relay is opened by the force of gravity and the starting winding circuit is broken.

## COMPRESSOR MOTOR

The compressor motor (sealed in the compressor housing) runs the compressor. It is started by the temperature control switch, the starting relay and the thermal overload switch. It is stopped by the temperature control switch; and, if it gets overloaded, by the thermal overload switch.

## THERMAL OVERLOAD ASSEMBLY

The thermal overload assembly (in the terminal box on the side of the compressor shell) is the name of a part that is made up of a switch (the thermal overload switch) and a heating wire. The heating wire is in the compressor motor's running and starting circuits. The thermal overload switch can complete or break the compressor motor's starting circuit and running circuit. If the compressor motor gets too warm, or draws too much current (which will make the heating wire get hot) the heat makes the thermal overload switch open in the running and starting circuit of the compressor and break those circuits. When the thermal overload assembly, the motor, and the compressor shell have all cooled enough to run safely, the thermal overload switch closes in these circuits and completes them.

## CONDENSER FAN MOTOR

The condenser fan motor (between the condenser and the motor compressor) runs a fan that sucks air through the condenser coils. It starts when the temperature control switch is closed and it stops when the temperature control switch is open.



HOW THE REFRIGERATION SYSTEM WORKS (Cont.)

ELECTRICAL OPERATION

What Does It	What Happens
<p>WHEN THE COOLER TEMPERATURE GETS UP TO THE CUT-ON SETTING</p>	
<p>The temperature control switch</p>	<p>Closes in the running winding circuit of the compressor motor and completes that circuit.</p> <p>Closes in the starting relay coil circuit, and completes that circuit.</p> <p>Closes in the starting winding circuit of the compressor motor.</p> <p>Closes in the condenser fan motor circuit, completing that circuit.</p>
<p>THE HEAVY CURRENT, DRAWN BY THE RUNNING WINDING, ALSO FLOWS IN THE STARTING RELAY COIL, AND:</p>	
<p>The starting relay coil</p>	<p>Closes the starting relay contacts in the starting winding circuit of the compressor motor, completing that circuit.</p>
<p>WHEN THE COMPRESSOR MOTOR GETS UP TO SPEED</p>	
<p>The force of gravity</p>	<p>Pulls the starting relay contacts apart because,</p>
<p>The starting relay coil</p>	<p>No longer gets enough current to hold the contacts closed, and</p>
<p>The starting relay contacts</p>	<p>Open in the starting winding circuit of the compressor motor, and break that circuit.</p>
<p>IF EITHER THE COMPRESSOR MOTOR OR THE CONDENSER FAN DRAWS TOO MUCH CURRENT AND CAUSES THE THERMAL OVERLOAD ASSEMBLY TO GET TOO WARM</p>	
<p>The thermal overload switch</p>	<p>Opens in the running winding circuit and the starting winding circuit of the compressor motor, and breaks both those circuits.</p> <p>Opens in the condenser fan motor circuit, and breaks that circuit.</p>

HOW THE REFRIGERATION SYSTEM WORKS (Cont.)

ELECTRICAL OPERATION (Cont.)

What Does It	What Happens
<p>WHEN THE THERMAL OVERLOAD ASSEMBLY COOLS DOWN AGAIN</p>	
<p>The thermal overload switch</p>	<p>Closes in both the running winding circuit and the starting winding circuit of the compressor motor.</p> <p>Closes in the condenser fan motor circuit, and completes that circuit.</p>
<p>WHEN THE COOLER TEMPERATURE GETS DOWN TO THE CUT-OFF SETTING</p>	
<p>The temperature control switch</p>	<p>Opens in the running winding circuit of the compressor motor, and breaks that circuit.</p> <p>Opens in the starting relay coil circuit, and breaks that circuit.</p> <p>Opens in the starting winding circuit of the compressor motor.</p>



## HOW THE REFRIGERATION SYSTEM WORKS (Cont.)

ELECTRIC CIRCUITS AND CIRCUIT DIAGRAMSCONDENSER FAN CIRCUIT

Switches In The Wiring	What The Switches Do	What Makes The Switches Work
Temperature control switch	Turns the condenser fan motor on and off.	The temperature in the cooling coil tank has come up to the cut-on point (1r gotten down to the cut-off point) set on the temperature control.
<u>COMPRESSOR MOTOR RUNNING WINDING CIRCUIT</u>		
Thermal over- load switch	Turns the running windings of the compressor motor on.	Current drawn by the motor or heat from the compressor can raise the temperature of the thermal overload assembly and make the thermal overload switch cut off.

HOW THE REFRIGERATION SYSTEM WORKS (Cont.)

ELECTRIC CIRCUITS AND CIRCUIT DIAGRAMS (Cont.)

CONDENSER FAN CIRCUIT DIAGRAM

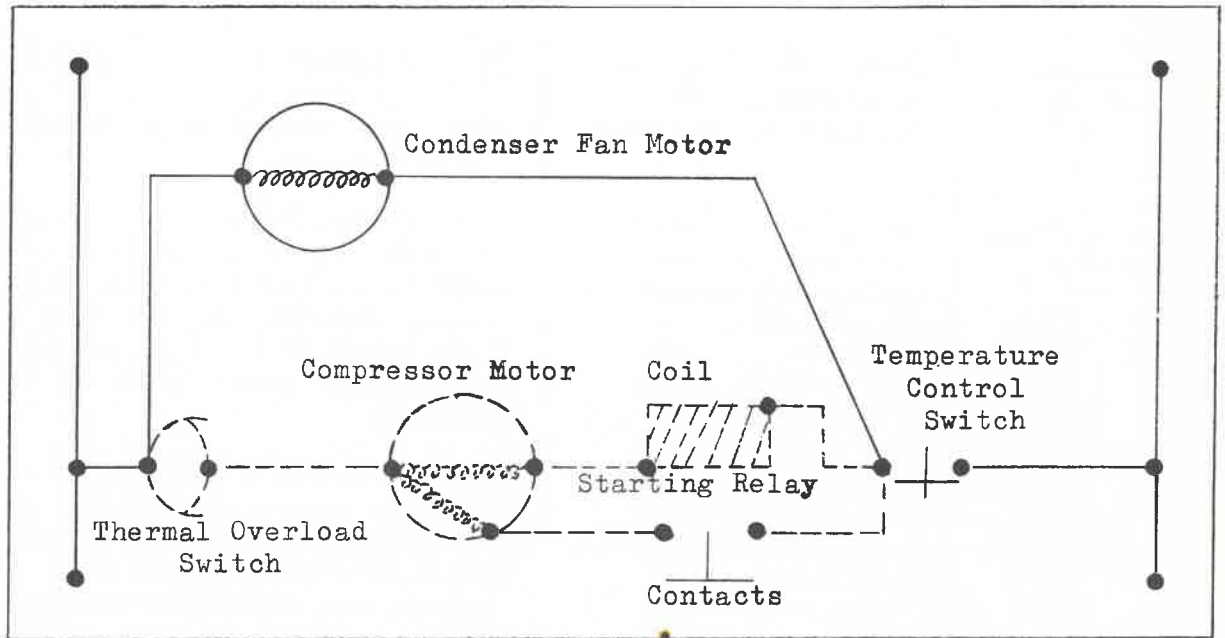

COMPRESSOR MOTOR RUNNING WINDING CIRCUIT DIAGRAM

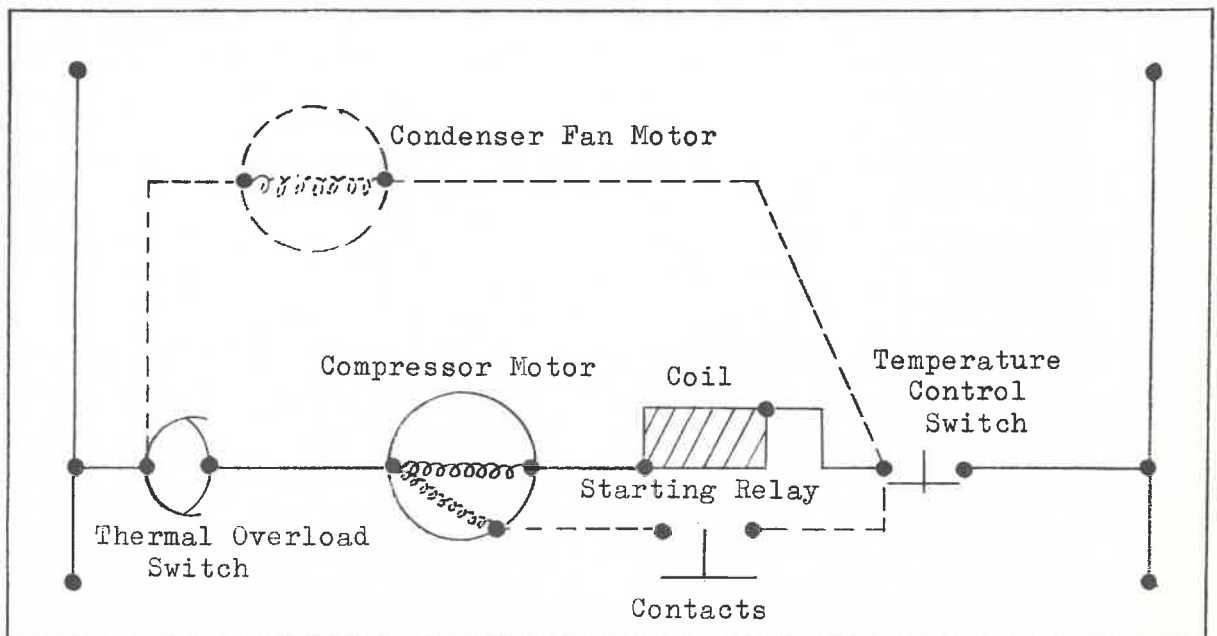

## HOW THE REFRIGERATION SYSTEM WORKS (Cont.)

ELECTRIC CIRCUITS AND CIRCUIT DIAGRAMS (Cont.)COMPRESSOR MOTOR STARTING WINDING CIRCUIT

Switches In The Wiring	What The Switches Do	What Makes The Switches Work
Temperature control switch	Turns the starting windings of the compressor motor on.	The temperature in the cooling coil tank has come up to the cut-on point set on the temperature control.
Starting relay contacts	Turns the starting windings of the compressor motor on and off.	The current drawn by the running winding of the compressor motor when it is first turned on also closes through the starting coil. This heavy current gives the relay coil enough power to close the contacts.
Thermal over- load switch	Turns the starting windings of the compressor motor on and off.	Current drawn by the motor or heat from the compressor can raise the temperature of the thermal overload assembly and make the thermal overload switch open.

HOW THE REFRIGERATION SYSTEM WORKS (Cont.)

ELECTRIC CIRCUITS AND CIRCUIT DIAGRAMS (Cont.)

COMPRESSOR MOTOR STARTING WINDING CIRCUIT DIAGRAM

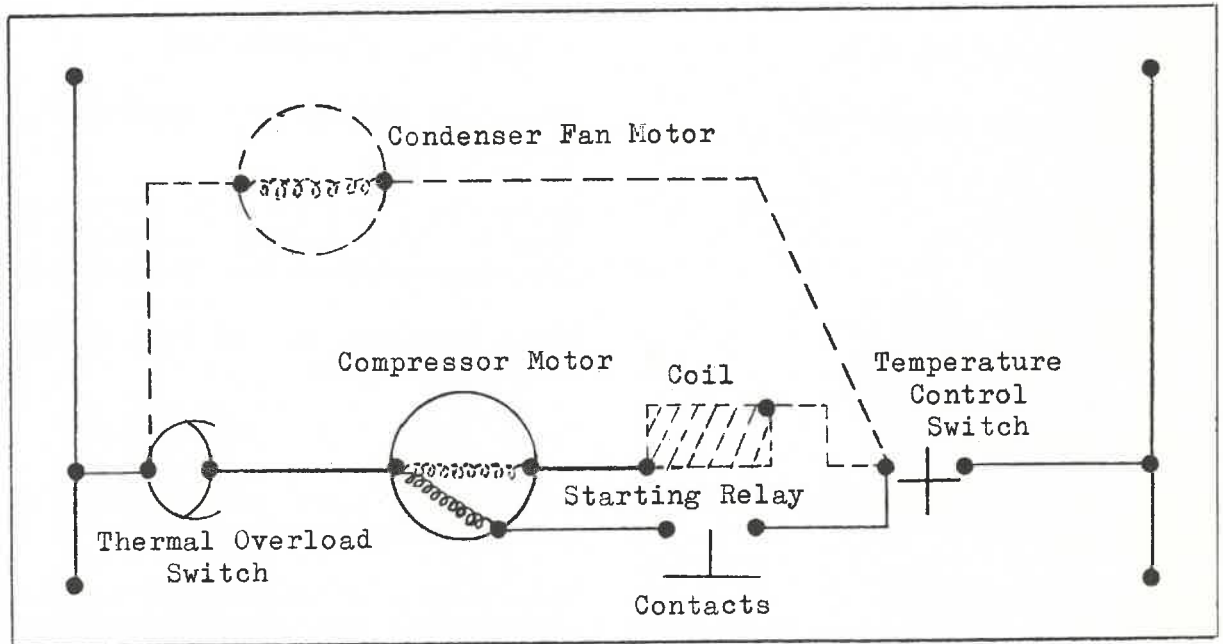

## HOW THE REFRIGERATION SYSTEM WORKS (Cont.)

REFRIGERATION CYCLEWhat Does ItWhat Happens

The rising temperature in the cooler	Warms the temperature control bulb and the liquid in it.
The liquid in the control bulb	Expands and pushes through the control tube and stretches the temperature control bellows.
The bellows	Moves, and closes the temperature control switch.
The temperature control switch	Turns the compressor motor on, Turns the condenser fan motor on.
The compressor motor	Drives the compressor.
The condenser fan motor	Drives the condenser fan.
The condenser fan motor	Sucks air through the condenser, cooling it.
The compressor	Sucks low pressure refrigerant gas from the evaporator, compresses the gas, and pumps it to the condenser.
The cooled condenser	Takes heat out of the high pressure refrigerant gas.
The cooled gas	Turns into liquid refrigerant.
More hot gas coming from the compressor	Pushes the liquid refrigerant into the capillary tube.
The capillary tube	Lets only a certain amount of liquid refrigerant run into the evaporator.
The evaporator	(Where the pressure is kept low by the suction of the compressor) heats the liquid refrigerant.
The liquid refrigerant	Changes into gas at low pressure and is sucked back into the compressor.
The falling temperature in the cooler	Cools the temperature control bulb and the liquid in it.



HOW THE REFRIGERATION SYSTEM WORKS (Cont.)

REFRIGERATION CYCLE (Cont.)

What Does It

What Happens

The liquid in the control bulb

Shrinks, and lets the temperature control bellows pull back.

The bellows

Move, and open the temperature control switch.

The temperature control switch

Turns the compressor motor off.  
Turns the condenser fan motor off.

The compressor

Stops.

The condenser fan motor

Stops.

(With the Cooler "plugged in" the evaporator fan motor runs constantly)

H O W T O T A K E C A R E O F  
T H E R E F R I G E R A T I O N S Y S T E M

WHAT TO CLEAN

Clean dirt and lint from the condenser with a brush, vacuum cleaner or compressed air.

WHEN AND WHAT TO LUBRICATE

The refrigeration system is sealed up and does not have to be oiled or greased. Enough oil is put into the condenser and fan motors when they are made to last as long as they will run.

THINGS TO ADJUST

TEMPERATURE CONTROL

The temperature control is on a bracket at the bottom right inside of the machine. The temperature control's outside range screw is on the side of the temperature control box and the inside range screw is under the fibre cover of the temperature control box.

OUTSIDE RANGE SCREW

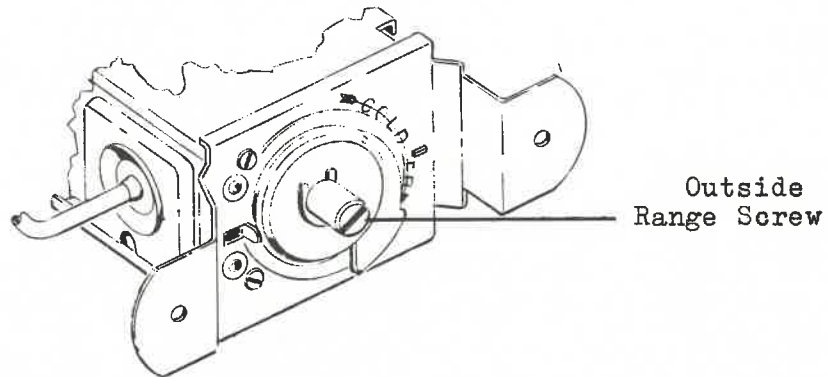

The temperature control is factory set to cut in at 36.5°F, (This is a constant cut-in temperature control) and cut-out at 19.0°F. To change the temperature control to a warmer cut-out setting, turn the outside range screw counter-clockwise and for a colder cut-out setting, turn the outside range screw clockwise. This will not change the cut-in temperature since it remains constant at 36.5°F, that is, until the inside range screw is turned.

HOW TO TAKE CARE OF  
THE REFRIGERATION SYSTEM (Cont.)

THINGS TO ADJUST (Cont.)

INSIDE RANGE SCREW

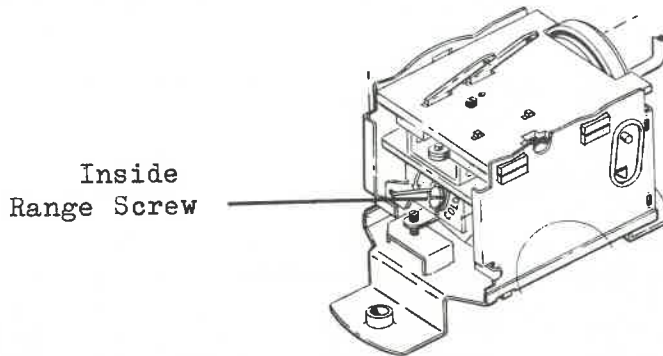

Ordinarily the inside range screw of the temperature control should require no adjustment. The two exceptions are adjustment to a warmer setting to compensate for altitudes of 1000 ft. or exceeding 1000 ft. above sea level, and frost on the evaporator that is not entirely removed during the off cycle.

To change the temperature control to a warmer cut-in and cut-out setting turn the screw clockwise. To change the temperature control to a colder cut-in and cut-out setting, turn the screw counter-clockwise.

ALTITUDE ADJUSTMENT

Turn the inside range screw clockwise for warmer temperature control setting to compensate for altitudes of 1000 ft. or more above sea level.

<u>Altitude Ft.</u>	<u>Turn Inside Range Screw</u>	<u>° of Compensation</u>
1000	1/8	1°
2000	1/4	2°
3000	3/8	3°
4000	1/2	4°

CORRECTING TROUBLES

When the refrigeration system is not working right, go to the table called "Correcting Common Refrigeration Troubles" on the next pages. Find your trouble, see what the possible causes are, and try the tests (in the center column); they will let you know when you have the true cause of the trouble. When you have found the cause of the trouble, either make the adjustment, repair the part or put a new part in, whatever the table says to do. This table does not list all of the possible causes of any of the troubles - - - but it does have all of the common causes. If your cooler has a trouble that is not shown on the chart, or the trouble is not the result of one of the causes shown on the chart, study the section on "How The Refrigeration Mechanism Works" and you will be able to find out what is wrong and fix it.

HOW TO TAKE CARE OF THE  
REFRIGERATION SYSTEM (Cont.)

TROUBLE

The Compressor Will Not Run At All . . . . .	19-R
The Compressor Starts But Will Not Keep Running . . . . .	21-R
The Compressor Runs But The Bottles Aren't Cold Enough . . . . .	23-R
The Refrigeration Unit Is Noisy . . . . .	26-R
The Compressor Motor Never Stops Running . . . . .	27-R

H O W T O C O R R E C T  
C O M M O N R E F R I G E R A T I O N T R O U B L E S (Cont.)

THE COMPRESSOR WILL NOT RUN AT ALL

<u>A Possible Cause Is</u>	<u>To Make Sure</u>	<u>This Is What To Do</u>
1. The cooler is not plugged in	Look; and if it isn't	Plug the cooler in.
2. The power is off	Plug a 110V lamp into the outlet. If it doesn't light,	Have someone, who knows how, get power to the outlet.
3. The refrigeration unit is not made for the voltage it is getting	Look at the nameplate on the cooler to find out what voltage and cycle it is made for. Ask the local power company if they supply this kind of current. If they don't,	Put a cooler in that is made for the kind of current you are getting.
4. A wire in the supply cord or control cable is broken,	Put the prods of 110V test lamp on terminal L of the starting relay and on terminal 3 of thermal overload switch (Make sure the temperature control switch is closed). If it doesn't light,	Put a new supply harness on.
5. The thermal overload switch is stuck open.	Unplug the cooler for at least 15 minutes. Then plug the cooler in and put the prods of a 110V test lamp on terminal L of the starting relay and on the common terminal of the compressor motor. If the lamp doesn't light,	Put a new thermal overload assembly in.
6. The temperature control bulb is either touching the evaporator or it is covered with ice and frost.	Look at it. If it is touching the evaporator or is covered with ice or frost,	Defrost the evaporator and be sure the bulb is mounted right.

## H O W T O C O R R E C T

## C O M M O N R E F R I G E R A T I O N T R O U B L E S (Cont.)

## THE COMPRESSOR WILL NOT RUN AT ALL (Cont.)

<u>A Possible Cause Is</u>	<u>To Make Sure</u>	<u>This Is What To Do</u>
7. The temperature control bellows do not work	Warm the temperature control bulb with your hand for about one minute. If the temperature control switch doesn't close,	Put a new temperature control in.
8. The temperature control switch contacts need cleaning.	Clean them and see if this helps.	Polish the faces of the contacts with "Cobehn".
9. The starting relay contacts aren't closing.	Warm the temperature control bulb to close the temperature control switch. If the starting relay contacts don't close at the same time,	Check the relay out as explained in the next two steps. If they do close, skip the next two steps and go on to step twelve of this section.
10.	Put the prods of a 110V test lamp across M of the relay and 3 of the overload protector. If the lamp does not light,	Put in a new relay.
11. The starting relay contacts are stuck open.	Warm the temperature control bulb to close the temperature control switch. If the starting relay contacts don't close when the temperature control switch does,	Put a new starting relay in.
12. The compressor motor's starting or running winding is burned out,	Unplug the cooler. Take all wires off the compressor terminals. Connect a 110V line to compressor motor terminals (C) and (R). At once, with an insulated wire, connect (for 2 seconds) compressor terminals (R) and (S). If the compressor does not start,	Put a new motor - compressor in.

H O W T O C O R R E C T  
C O M M O N R E F R I G E R A T I O N T R O U B L E S (Cont.)

THE COMPRESSOR STARTS, BUT WILL NOT KEEP RUNNING

<u>A Possible Cause Is</u>	<u>To Make Sure</u>	<u>This Is What To Do</u>
1. The thermal over-load switch opens every time, or almost every time, the compressor motor starts.	Wait until the compressor motor stops, then unplug the cooler and open the temperature control switch is closed. If it is,	Check the "Possible Causes" in the next 6 steps. If it is not, skip the next 6 steps and go to step 8 of this section.
2. The tube from the compressor to the condenser is kinked or bent sharply.	Look; if it is,	Try to get the kink out.
3. The capillary tube is kinked or bent sharply.	Look; if it is,	Try to get the kink out.
	If this does not help and no other cause can be found for the trouble,	Put a new capillary tube on.
4. The starting relay contacts are sticking closed.	Plug the cooler back in. Then while the compressor is running see if the starting relay contacts stay closed. If they do,	Clean the relay contacts with "Cobehn".
	If the starting relay contacts stick closed again after cleaning,	Put a new starting relay in.
5. The voltage at the cooler is either too high or too low.	1. When an extension cord is not used on the supply cord; While the compressor is running put one prod of a volt meter on terminal (L) of the starting relay and the other prod on terminal (M) of the starting relay. If the voltage is not between 105V and 126V,	Have the person in charge of the cooler tell the power company so they can take care of it.

HOW TO CORRECT  
COMMON REFRIGERATION TROUBLES (Cont.)

THE COMPRESSOR STARTS, BUT WILL NOT KEEP RUNNING (Cont.)

<u>A Possible Cause Is</u>	<u>To Make Sure</u>	<u>This Is What To Do</u>
	<p>2. When an extension is used on the supply cord: Put a double socket on the plug end of the extension and plug it into the outlet. While the compressor is running, put the prods of a volt meter into one of the other sides of the double socket. If the voltage is not between 105V and 126V,</p>	<p>Have the person in charge of the cooler tell the power company so they can take care of it.</p>
<p>6. The cut-on temperature is set too close to the cut-off temperature.</p>	<p>Put a thermometer on the control bulb. Read the temperature when the refrigeration unit cuts on. Read the temperature again when it cuts off. If the two temperatures are less than 16°F apart.</p>	<p>Turn the outside range screw clockwise.</p>
<p>7. The thermal overload switch opens after the compressor has been running a short time, but before the temperature control switch cuts off.</p>	<p>Wait until the compressor stops, then unplug the cooler and open the temperature control box, to see if the temperature control switch is closed. If it is,</p>	<p>Check the "Possible Causes" in the next 3 steps.</p>
<p>8. Not enough air is getting to the condenser.</p>	<p>See if there is anything around the outside of the cooler. If there is</p>	<p>Take it away.</p>
<p>9. The condenser is dirty.</p>	<p>Look. Also feel the tube from the compressor to the condenser. If the tube is very hot, or if you see dirt on the condenser,</p>	<p>Clean the condenser with either a vacuum cleaner, a brush or compressed air.</p>
<p>10. The condenser fan motor is burned out.</p>	<p>With the condenser fan motor leads correctly connected to the compressor motor terminals (see wiring diagram) see if the condenser fan runs when the compressor does. If it doesn't,</p>	<p>Put a new condenser fan motor in.</p>



HOW TO CORRECT  
COMMON REFRIGERATION TROUBLES (Cont.)  
THE COMPRESSOR RUNS BUT THE BOTTLES AREN'T COLD ENOUGH

<u>A Possible Cause Is</u>	<u>To Make Sure</u>	<u>This Is What To Do</u>
1. The evaporator fan is not working.	Look. If it is not working,	Check the "Possible Cause" in the next step. If it is working, skip the next step and go on to setp 3 of this section.
2. The evaporator fan motor is burned out.	Remove black rubber junction block located on the fan motor bracket. Connect a 110V line to the evaporator fan motor leads. If the evaporator fan motor doesn't start,	Put a new evaporator fan motor in.
3. The temperature control cam is set too warm (high).	Turn the outside range screw of the temperature control clockwise to a colder setting and let the cooler run overnight. If the bottles get cold enough,	Leave the temperature control at that setting.
4. The evaporator is covered with frost and ice.	If the bottles did not get colder,	Put a new temperature control in.
4. The evaporator is covered with frost and ice.	Look at it.	Defrost the evaporator, then check the "Possible Causes" in the next two steps. If it isn't, skip the next two steps and to to setp 8 of this section.
5. The temperature control cam is set too cold and the evaporator is not defrosting.	Look at the evaporator for frost, if there is frost,	Turn the inside range screw.
	If the evaporator coil does not defrost on each cycle,  If, after the second setting, the coil still does not defrost,	Turn the inside range screw.  Put a new temperature control in.

H O W T O C O R R E C T  
C O M M O N R E F R I G E R A T I O N T R O U B L E S (Cont.)

T H E C O M P R E S S O R R U N S B U T T H E B O T T L E S A R E N ' T C O L D E N O U G H (Cont.)

A Possible Cause Is	To Make Sure	This Is What To Do
6. The temperature control switch contacts stick closed.	If the unit runs all the time, and the evaporator builds up frost,	Put a new temperature control in.
7. The temperature control bulb sleeve is touching the evaporator.	Look at it. If it is touching the evaporator tube,	Bend the bracket so that there will be space between the bulb sleeve and the evaporator tube.
8. The control bulb is not in the sleeve (holder).	Look. If it is not,	Put the bulb in the sleeve (holder).
9. The temperature control bellows is not working.	Warm the temperature control bulb with your hand for about one minute. If the temperature control switch doesn't close,	Put a new temperature control in.
10. The refrigerant tubing is kinked or bent sharply.	Look. If it is,	Try to get the kink out.
11. There isn't enough refrigerant in the refrigeration system or the capillary tube is partly plugged.	If this does not help and no other cause can be found for the trouble,  Let the cooler run at least 15 minutes and then see if the evaporator is frosted all over. If it isn't,	Put some new refrigerant tubing in.  Try to blow the plug out of the capillary tube, evacuate the system and then put a new charge of gas in the refrigeration unit.
12. The condenser isn't getting enough air.	See if there is anything around the outside of the cooler to keep the air out. If there is,	Take it away.
13. The condenser is dirty.	Look. Also feel the tube from the compressor to the condenser. If the tube is very hot, or if you see dirt,	Clean the condenser with either a vacuum cleaner, a brush or compressed air.

HOW TO CORRECT  
COMMON REFRIGERATION TROUBLES (Cont.)

THE COMPRESSOR RUNS BUT THE BOTTLES AREN'T COLD ENOUGH (Cont.)

A Possible Cause Is	To Make Sure	This Is What To Do
<p>14. The condenser fan motor is burned out.</p>	<p>With the condenser fan motor leads correctly connected to the compressor terminal, see if the condenser fan runs when the compressor does. If it doesn't,</p>	<p>Put a new condenser fan motor in.</p>
<p>15. The thermal overload switch is starting and stopping the compressor</p>	<p>Unplug the cooler for at least 15 minutes, then plug it in again. Be sure the temperature control switch is closed. (Warm the temperature control bulb with your hand to close it.) If the compressor motor cuts off, then on, then off, while the temperature control switch stays closed,</p>	<p>Check the "Possible Causes" in steps 16 and 17.</p>
<p>16. The voltage at the cooler is either too high or too low.</p>	<p>1. When an extension is not used on the supply cord: While the compressor is running put one prod of a volt meter on terminal (S) of starting relay and the other prod on terminal (L) of the starting relay. If the voltage is not between 105V and 126V,</p> <p>2. When an extension is used on the supply cords: Put a double socket on the plug end of the extension and plug it into the outlet. While the compressor is running, put the prods of a volt meter on terminal (S) of the starting relay and the other prod on terminal (L) of the starting relay. If the voltage is not between 105V and 126V,</p>	<p>Have the person in charge of the cooler tell the power company so they can take care of it.</p> <p>Have the person in charge of the cooler tell the power company so they can take care of it.</p>

HOW TO CORRECT

COMMON REFRIGERATION TROUBLES (Cont.)

THE COMPRESSOR RUNS BUT THE BOTTLES AREN'T COLD ENOUGH (Cont.)

A Possible Cause Is	To Make Sure	This Is What To Do
<p>17. The starting relay contacts are sticking closed.</p>	<p>Look and see. If they are,</p> <p>THE BOTTLES ARE TOO COLD</p>	<p>Put a new starting relay in.</p>
<p>1. The temperature control bulb is not in its sleeve (holder).</p>	<p>Look and see. If it isn't,</p>	<p>Put the bulb in its sleeve (holder).</p>
<p>2. The temperature control cam is set too cold.</p>	<p>Turn the outside range screw of the temperature control cam counter-clockwise to a warmer setting and let the cooler run over night. If the bottles get cold enough but not too cold,</p>	<p>Leave the temperature control cam at that setting.</p>
<p>3. The temperature control switch is stuck closed.</p>	<p>Unplug the cooler and let the evaporator fan come to a stop. Then block the fan blade so it can't turn. Remove the temperature control bulb from its sleeve (holder) and touch it to the evaporator tube. Plug the cooler back in and let the compressor run until it cuts off, but not more than 30 minutes. If the cooler has not cut off,</p>	<p>Put a new temperature control in.</p>
<p>THE REFRIGERATION UNIT IS NOISY</p>		
<p>1. The refrigerant lines rattle.</p>	<p>Hold them between your fingers. If the rattle stops,</p>	<p>Bend them gently away from whatever they are hitting.</p>

HOW TO CORRECT  
COMMON REFRIGERATION TROUBLES (Cont.)

THE COMPRESSOR MOTOR NEVER STOPS RUNNING

A Possible Cause Is	To Make Sure	This Is What To Do
<p>1. The temperature control switch is stuck closed.</p> <p>2. The compressor has a broken valve or no refrigerant in the refrigeration system.</p>	<p>Turn the inside range screw cam and the range screw to their warmest settings. Let the cooler run overnight, or until it stops. If the compressor motor doesn't stop running,</p> <p>The tube from the compressor to the condenser is not warm and the evaporator is not cold,</p> <p>If this does not help,</p>	<p>Put a new temperature control in.</p> <p>Put a new charge of refrigerant in the refrigeration unit.</p> <p>Put a new motor compressor in the refrigeration unit.</p>

HOW TO CORRECT  
COMMON REFRIGERATION TROUBLES  
WIRING DIAGRAM

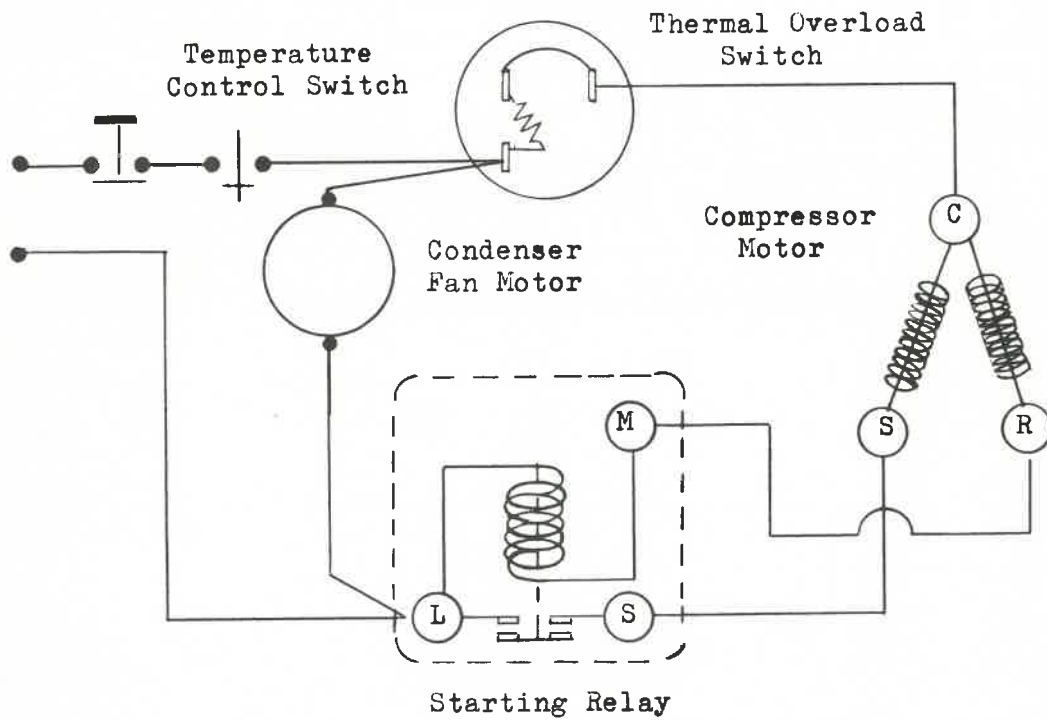

REFRIGERATION

PARTS LIST

CONTENTS

---

REFRIGERATION UNIT REPLACEMENT . . . . .	} PAGE 31-R
EVAPORATOR FAN AND FAN MOTOR . . . . .	
EVAPORATOR . . . . .	
CONTROL, TEMPERATURE . . . . .	
COMPRESSOR MOTOR REPLACEMENT . . . . .	} PAGE 33-R
RELAY . . . . .	
OVERLOAD PROTECTOR . . . . .	
CONDENSER FAN AND FAN MOTOR . . . . .	
CONDENSER . . . . .	
SOAKERS . . . . .	

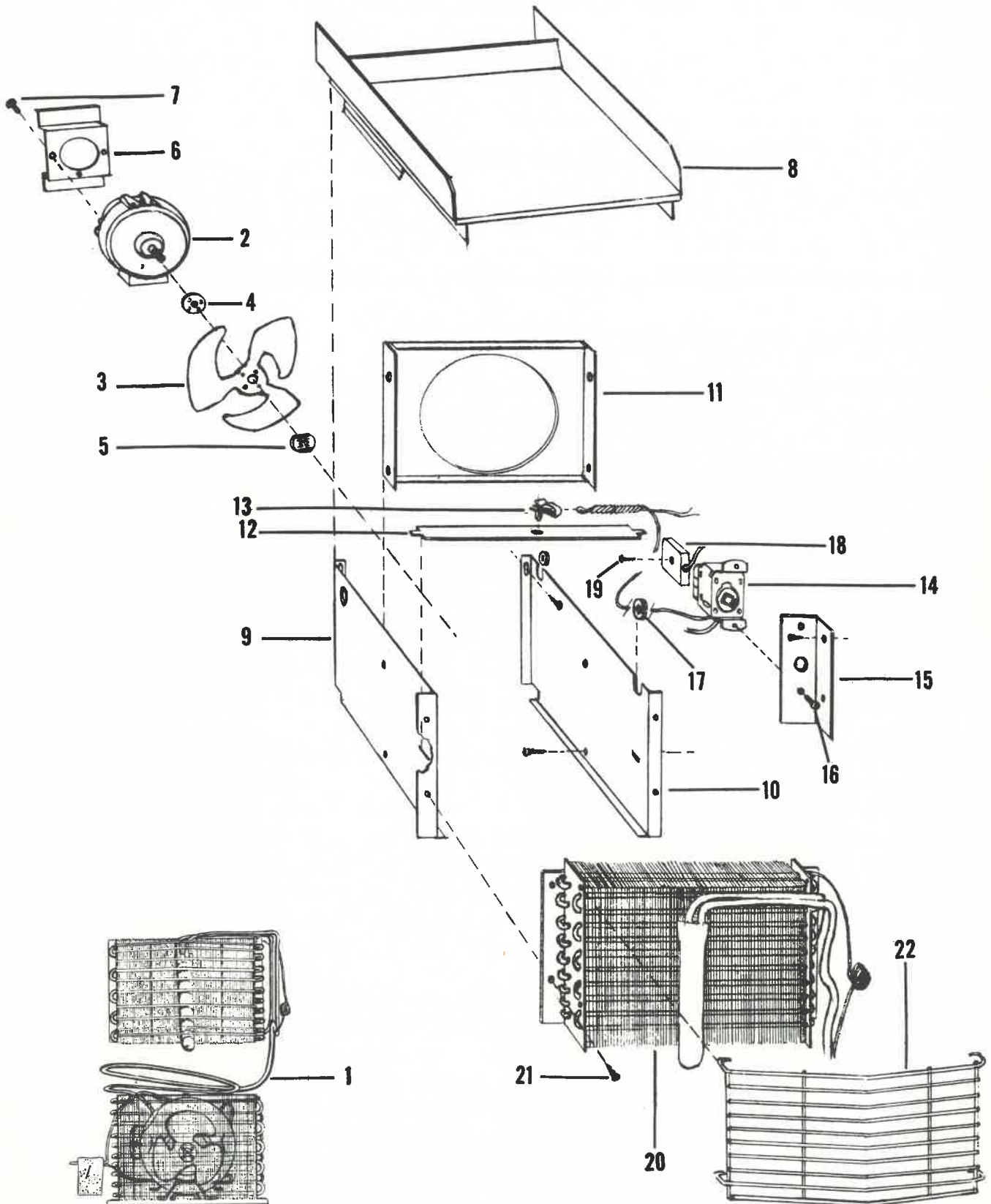

REFRIGERATION



REFRIGERATION

INDEX NO.	P A R T N U M B E R			PART NAME AND DESCRIPTION
	DNS-80	DNS-110	DNS-150	
1	AS-0070	A52-01-70	A52-01-70	Refrigeration Unit, Replacement (Less Condenser and Evaporator Fan Motor Assemblies
2	- - - - -	VS23-0212	- - - - -	Fan Motor - Evaporator
3	- - - - -	VS1-0337	- - - - -	Fan Blade - Evaporator Fan Motor
4	- - - - -	DN45-0017	- - - - -	Silencer, Neoprene
5	- - - - -	DN9-0013	- - - - -	Nut, Tinnerman
6	- - - - -	B52-04-02A	- - - - -	Bracket, Evaporator Fan Motor
7	- - - - -	DN3-0032	- - - - -	Screw, Hex Head, Type F, #10-24 x 3/8
8	- - - - -	B52-04-08	- - - - -	Top Panel - Fan Housing
9	- - - - -	B52-04-14	- - - - -	Left Side Panel - Fan Housing
10	- - - - -	B52-04-13	- - - - -	Right Side Panel - Fan Housing
11	- - - - -	B52-04-15	- - - - -	Shroud - Evaporator Fan
12	- - - - -	B52-04-12	- - - - -	Bracket - Temperature Control Bulb
13	- - - - -	DN9-0063	- - - - -	Clamp, Temperature Control Bulb
14	- - - - -	DN28-0009	- - - - -	Temperature Control
15	- - - - -	B52-04-01	- - - - -	Bracket, Temperature Control
16	- - - - -	DN3-0003	- - - - -	Screw, #8 x 3/8, Type Z
17	- - - - -	DN20-0019	- - - - -	Grommet
18	- - - - -	VS23-0194	- - - - -	Junction Block
19	- - - - -	VS6-0084	- - - - -	Screw, #10 x 1-1/4, Type Z
20	- - - - -	CDN26-0007	- - - - -	Evaporator
21	- - - - -	VS6-0023	- - - - -	Screw, #8 x 1/2, Type A
22	- - - - -	CDN14-0055	- - - - -	Wire Guard

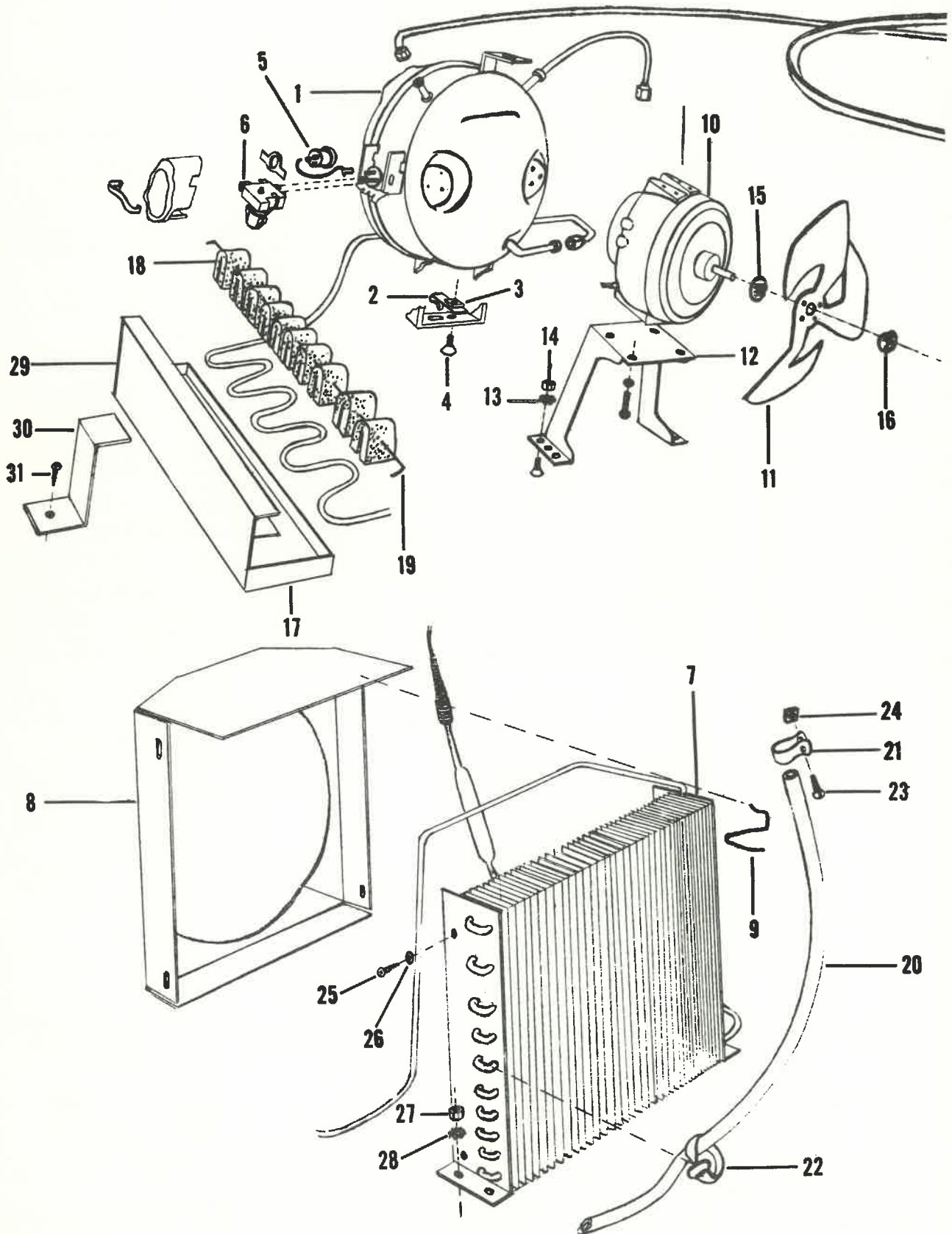

REFRIGERATION

REFRIGERATION

INDEX NO.	P A R T N U M B E R			PART NAME AND DESCRIPTION
	DNS-80	DNS-110	DNS-150	
1	AS-0069	A52-01-110	A52-01-110	Compressor, Motor, Replacement
2	-----	DN9-0060	-----	"J" Nut, Compressor
3	-----	VS30-0046	-----	Lockwasher, Split for 5/16
4	-----	VS9-0072	-----	Cap Screw, 5/16 x 18 x 3/4 Hex Head
5	82626	82621	82621	Relay, Starting, Plug In Type
6	83715	83421	83421	Thermal Overload Assembly
7	-----	VS8F-0054	-----	Condenser
8	-----	VS21-0016	-----	Shroud
9	-----	VS29-0039	-----	Clip, Shroud
10	-----	VS23-0212	-----	Fan Motor, Condenser
11	-----	VS1-0097	-----	Fan Blade, Condenser
12	-----	VS1-0297	-----	Fan Bracket, Condenser
13	-----	VS30-0076	-----	Lockwasher, For 1/4
14	-----	VS9-0048	-----	Nut, Hex, #1/4 x 20
15	-----	DN45-0017	-----	Silencer, Neoprene
16	-----	DN9-0013	-----	Nut, Tinnerman
17	-----	B52-04-04	-----	Condensate Pan
18	-----	DN19-0002	-----	Soakers, Condensate
19	-----	DN50-0034	-----	Retainer Rod
20	-----	DN19-0037	-----	Flexible Drain Hose
21	-----	DN9-0065	-----	Hose Clamp
22	-----	DN9-0074	-----	Hose Clamp
23	-----	VS9-0209	-----	Screw, #10-32 x 1-1/2
24	-----	VS9-0096	-----	Nut, Hex, #10-32
25	-----	DN3-0016	-----	Screw, #6 x 3/8
26	-----	DN7-0005	-----	Washer, Flat for #6
27	-----	VS9-0048	-----	Hex Nut, #1/4 - 20
28	-----	VS30-0076	-----	Lockwasher, #1114
29	-----	B52-04-23	-----	Tube Holder - Discharge Line
30	-----	A52-04-03	-----	Angle - Tube Holder
31	-----	DN3-0016	-----	Screw, #6 x 3/8

C

C

C